

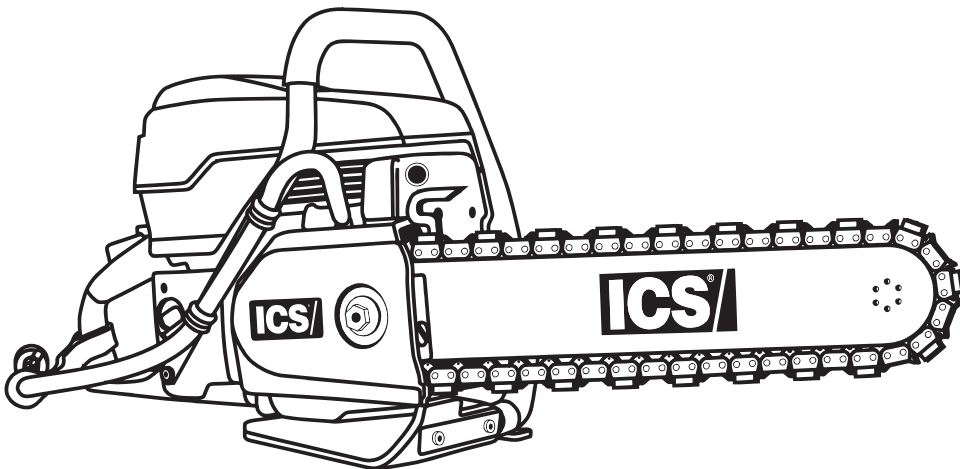

Diamond Tools and Equipment
for Construction and Infrastructure

695GC/F4



SERVICE MANUAL

SECTION	SECTION TITLE	PAGE NUMBER
	SERVICE MANUAL USE	3
1	TOOLS	4
2	SAW SPECIFICATIONS	5
3	SERIAL NUMBER LOCATION	6
4	SPARE PARTS DIAGRAM (TORQUE SPECIFICATIONS AND LOCTITE® APPLICATION)	7
5	AIR INTAKE	19
6	SPARK PLUG	20
7	SIDE COVER & TENSIONER	22
8	CLUTCH & RIM SPROCKET	24
9	STARTER SYSTEM	30
10	CARBURETOR REMOVAL	35
11	MUFFLER/W BAR STUD	39
12	MUFFLER/W BAR STUD	40
13	IGNITION MODULE	41
14	STOP SWITCH	42
15	WATER HOSE	44
16	CYLINDER & PISTON	45
17	BOTTOM GUARD/FRONT HANDLE	51
18	REAR HANDLE	53
19	FUEL TANK & COMPONENTS	57
20	CRANKCASE	63
21	CARBURETOR TUNING	77
22	IDLE SPEED ADJUSTMENT	80
23	TROUBLESHOOTING DIAGRAMS	81
24	TROUBLESHOOTING: FUEL SYSTEM	83
25	TROUBLESHOOTING: CRANKCASE LEAKS	87
	APPENDIX	
	1. SPARK PLUG REFERENCE GUIDE	89

Service Manual Use

This manual contains all the technical information necessary for carrying out repairs on the 695GC/F4 saw. For safe, efficient work, it is of prime importance that the values indicated be adhered to. Routine periodic maintenance is covered in the operator's manual included with each saw.

General Service Rules

- Always use the right tools for the job, otherwise components may be damaged.
- Use a plastic dead blow mallet to separate parts attached solidly to each other.
- Mark mating parts as a reassembly reference.
- Keep component parts together as a group. Assemble screws and nuts into appropriate subgroups.
- When reassembling, clean all parts carefully, lubricate moving parts and replace all oil seals, o-rings, gaskets, washers and self-locking nuts.
- **For best results, use only original ICS® replacement parts.**

General Recommendations

- Some procedures in this manual require the use of special tools. These are noted in the service manual.
- Detailed carburetor maintenance and overhaul information is available in Walbro's Diaphragm Carburetor Service Manual. Walbro can be contacted at <http://www.walbro.com> or by calling 1.989.872.2131.

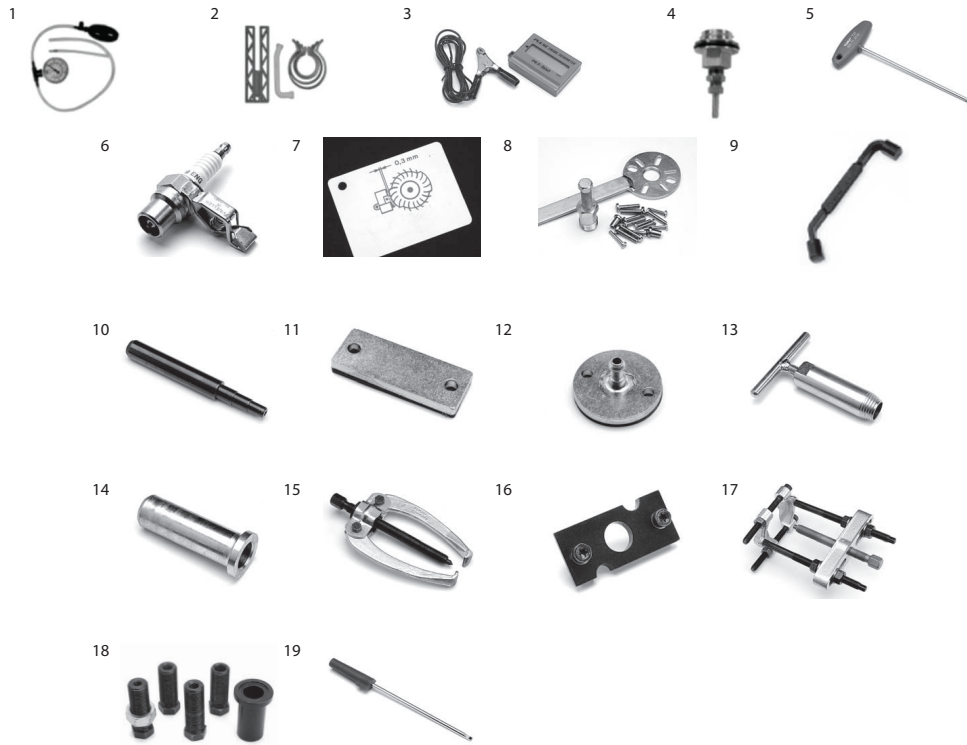

Key #	Part No.	Description
1	71541	Pressure Gauge Bulb
2	71543	Cylinder Assembly Clamps & Piston Stop
3	71565	Electronic Tachometer
4	73425	Fuel Tank Pressure Cap
5	546191	Workshop Key Torx T27
6	546192	Test Spark Plug
7	546193	Air Gap Gauge
8	546194	Flywheel Puller
9	547277	Piston Stop
10	546196	Wrist Pin Punch
11	546197	Cylinder Seal, Exhaust
12	546198	Cylinder Seal, Inlet Port
13	546289	Puller, Sealing Ring
14	546291	Assembly Punch
15	546292	Universal Puller
16	546293	Grip Plate
17	546294	Bearing Puller
18	546295	Bearing Press
19	546307	Screwdriver, Idle
not shown	546659	Clutch Tool
not shown	70249	14T Bar Nose Sprocket Repair Kit (for 695GC)
not shown	530046	FORCE4™ Bar Nose Sprocket Repair Kit (for 695F4)
not shown	505882	2-Stroke Oil, 25:1 Mix, 5.2 oz. (158 ml) (6-pack)
not shown	505883	2-Stroke Oil, 25:1 Mix, 5.2 oz. (158 ml) (24-pack)

Specifications

Engine Type	2-stroke, Air Cooled
Displacement	5.7 cu-in (94 cc)
Horsepower	6.4 hp (4.8 kW) @ 9000 rpm
Torque	50.4 in-lbs (5.7 Nm) @ 7,200 rpm
Engine Speed	9,300 +/- 150 rpm (max) 2,700 +/- 100 rpm (idle)
Piston ring gap (Maximum)	.04 in/1.0mm
Weight	21 lbs (9.5 kg) powerhead only
Dimensions	18 in (46 cm) length 14 in (36 cm) height 12 in (30 cm) width
Carburetor	Walbro RWJ-5A
Air Filtration	Water resistant polyester
Starter	Dust and water resistant
Ignition	Special water resistant electronic ignition
Spark plug type	NGK BPMR7A or Champion RCJ6Y Electrode gap 0.020 in (0.5 mm)
Clutch	Centrifugal, three shoe, three spring
Fuel Mix Ratio	25:1 (4%) gasoline-to-oil
Fuel Capacity	0.26 gallon (1 liter)
Water Supply	Minimum 20 psi (1.5 bar)
Noise Level	112 dB(A) at 3 ft (1 m)
Vibration Level	3.9 m/s ² (front handle) 4.1 m/s ² (rear handle)

3. This section shows the single location of the serial number.



4. This section covers spare parts.

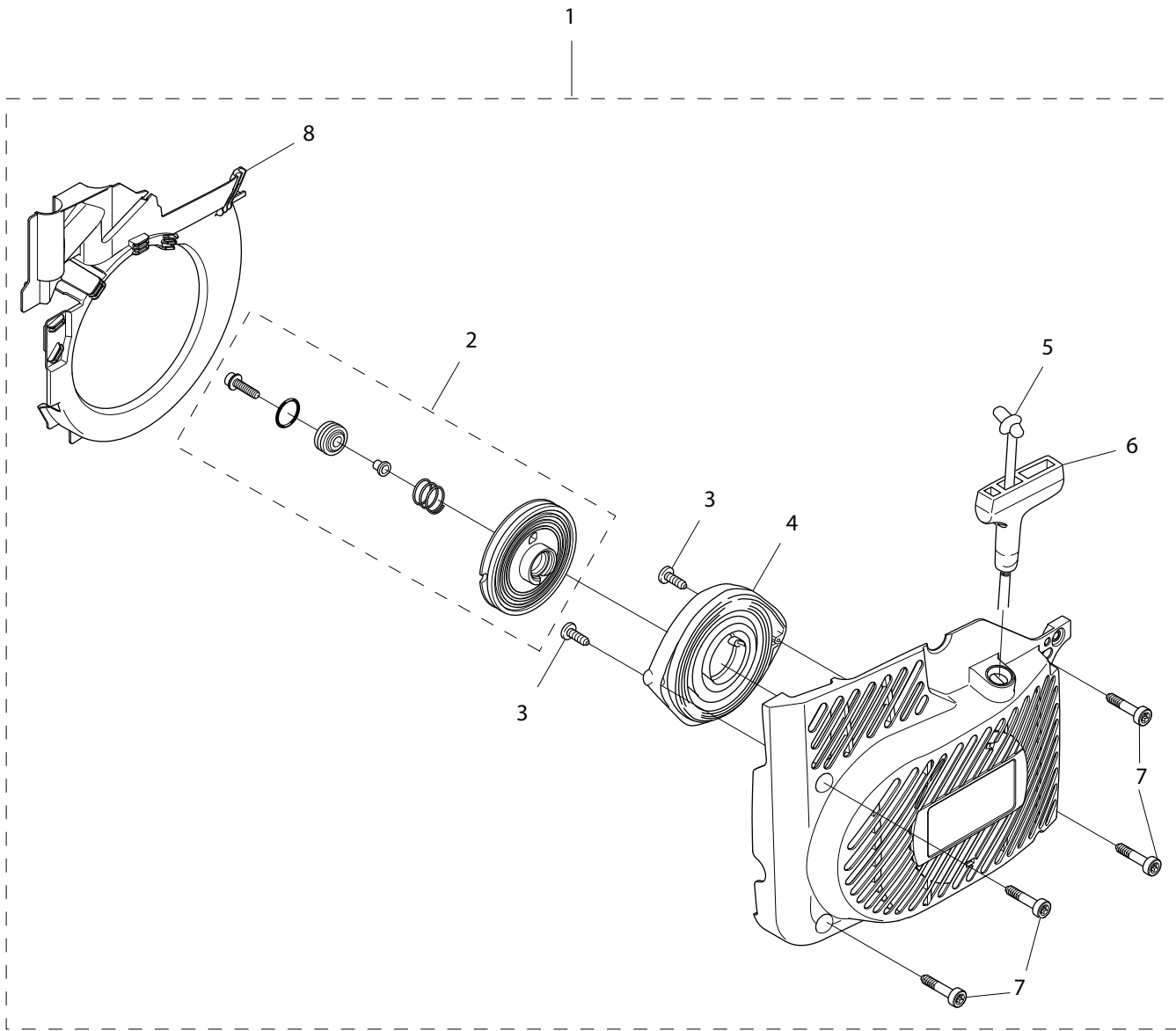

STARTER ASSEMBLY

KEY	DESCRIPTION	TORQUE		LOCTITE® 242	PART NUMBER
		Nm	in-lbs.		
1	STARTER COVER ASSEMBLY				544013
2	STARTER PULLEY KIT				544127
3	SCREW			x	543974
4	RECOIL SPRING				544021
5	STARTER CORD				544023
6	STARTER HANDLE				544024
7	SCREW	7 - 9	60 - 78		544012
8	STARTER COVER SHIELD				544026

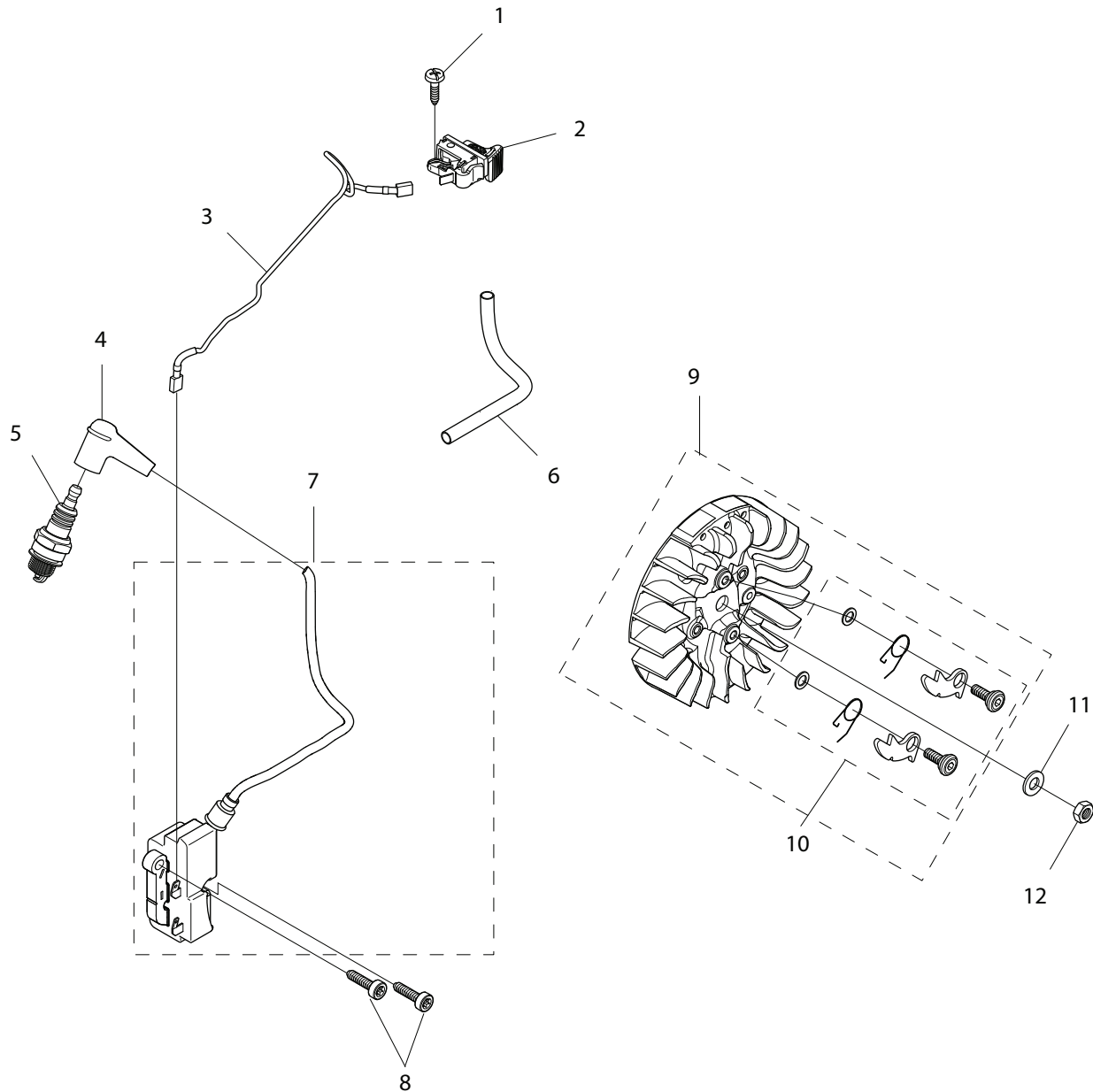

FLYWHEEL & IGNITION ASSEMBLY

KEY	DESCRIPTION	TORQUE		LOCTITE® 242	PART NUMBER
		Nm	in-lbs.		
1	STOP SWITCH SCREW			x	544030
2	STOP SWITCH				544031
3	STOP SWITCH CABLE				544032
4	SPARK PLUG CAP				544033
5	SPARK PLUG				544034
6	PROTECTIVE SLEEVE				544035
7	IGNITION MODULE				544036
8	IGNITION MODULE SCREW	10 - 12	89 - 105	x	544038
9	FLYWHEEL				544053
10	STARTER PAWL KIT (INCL. TWO OF EACH ITEM)				544125
11	FLYWHEEL WASHER				544058
12	FLYWHEEL NUT	25 - 30	216 - 264		544059

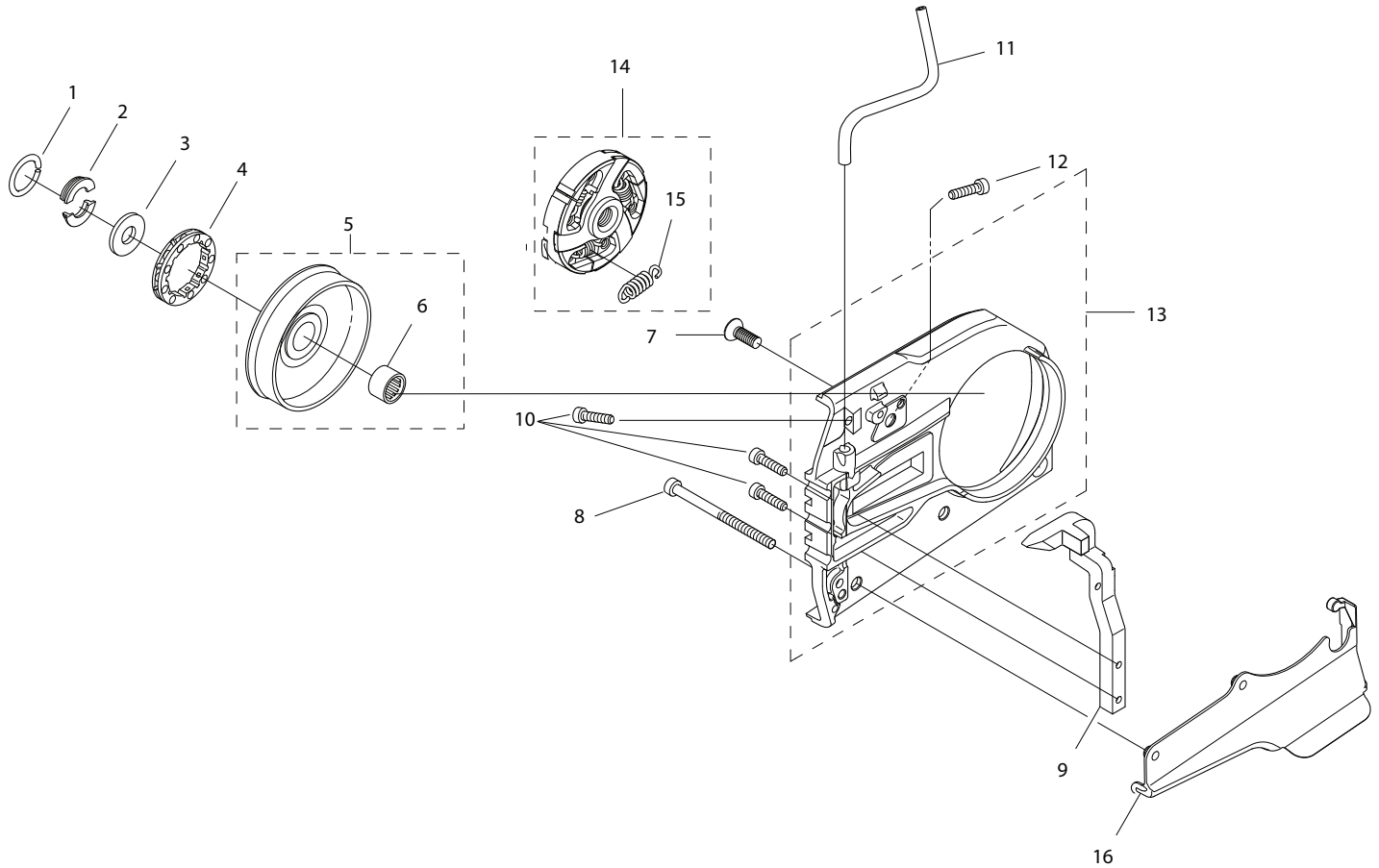

CLUTCH ASSEMBLY & WALLWALKER®

KEY	DESCRIPTION	TORQUE		LOCTITE® 242	PART NUMBER
		Nm	in-lbs.		
1	RETAINING RING				543905
2	SPLIT RETAINER				543906
3	SPACER				543907
4	695F4 FORCE4™ SPROCKET				525496
4	695GC RIM SPROCKET				70949
5	CLUTCH CUP				543909
6	NEEDLE BEARING				543910
7	BAR BRACKET SCREW			x	543911
8	CRANK CASE BOLT			x	543912
9	WALLWALKER®				544130
10	WALLWALKER® SCREW				543920
11	WATER PIPE				543915
12	WATER PIPE SCREW			x	546548
13	BAR BRACKETS				543916
14	CLUTCH ASSEMBLY				547856
15	CLUTCH SPRING				543928
16	SHIELD				544137

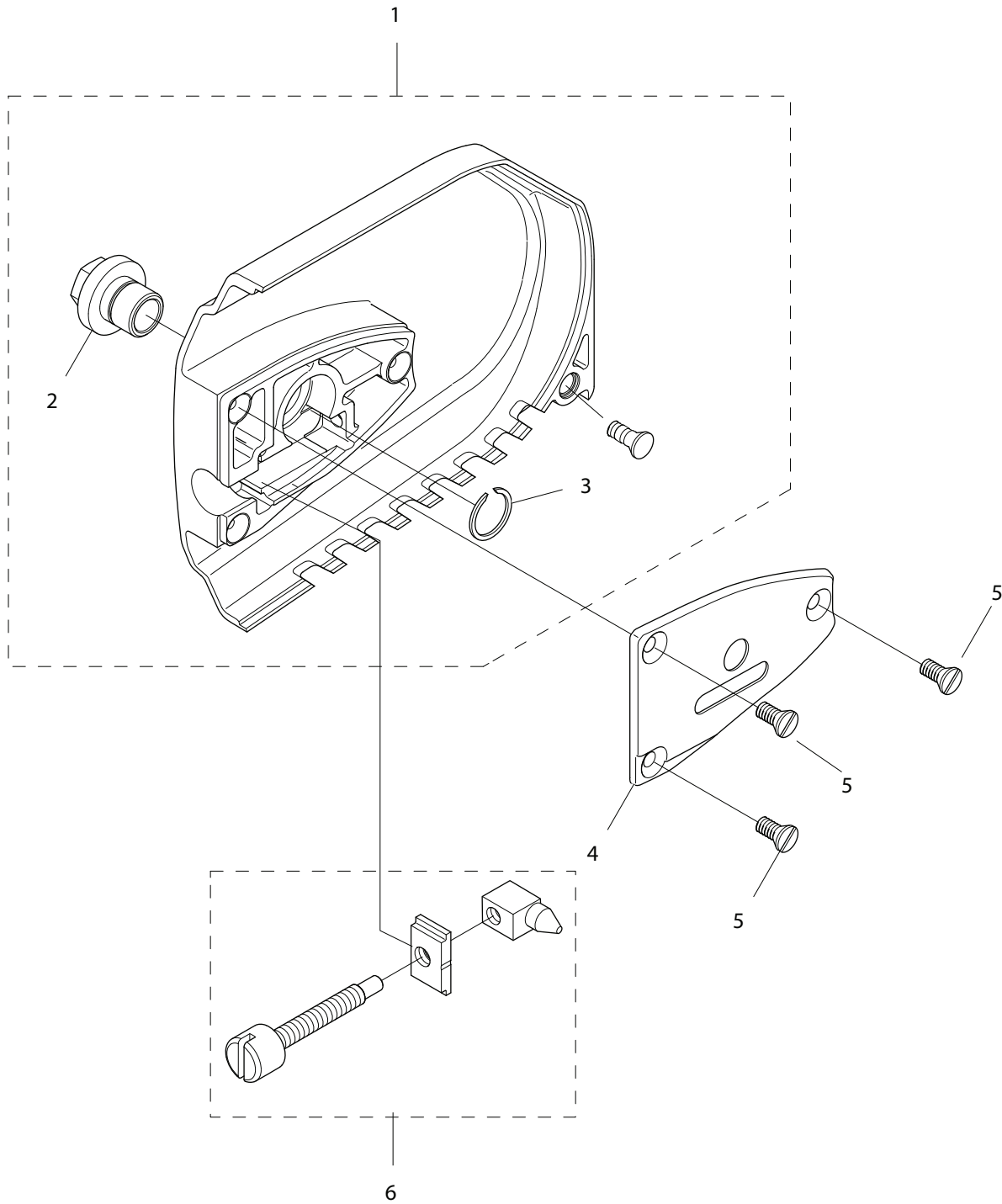

SIDE COVER & TENSIONER ASSEMBLY

KEY	DESCRIPTION	TORQUE		LOCTITE® 242	PART NUMBER
		Nm	in-lbs.		
1	SIDE COVER ASSEMBLY				543899
2	SIDE COVER NUT	27 - 34	240 - 300		543900
3	SIDE COVER NUT CIRCLIP				543901
4	TENSIONER COVER PLATE SCREW				543902
5	SCREW, SIDE COVER CAP			x	543903
6	TENSIONER				543904

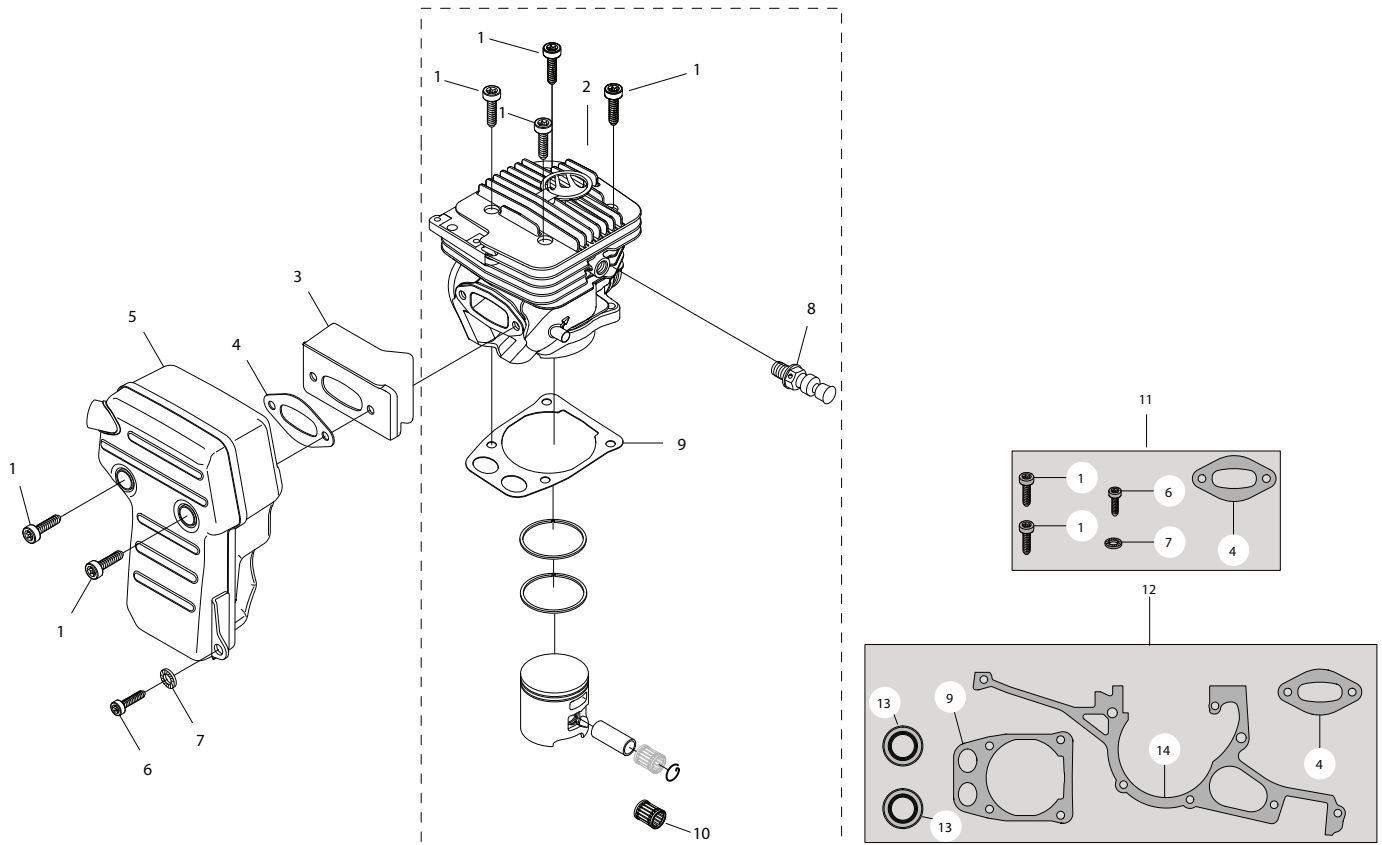

CYLINDER & EXHAUST ASSEMBLIES

KEY	DESCRIPTION	TORQUE		LOCTITE® 242	PART NUMBER
		Nm	in-lbs.		
1	CYLINDER/MUFFLER SCREW	15 - 18	132 - 156	x	543942
2	PISTON/CYLINDER KIT				545873
3	HEAT DEFLECTOR				543844
4	MUFFLER GASKET				543938
5	MUFFLER				543845
6	LOWER MUFFLER MOUNTING SCREW			x	543846
7	MUFFLER MOUNTING WASHER				543847
8	DECOMPRESSION VALVE				543848
9	CYLINDER BASE GASKET				543937
10	NEEDLE BEARING				543949
11	MUFFLER MOUNT KIT				543950
12	GASKET KIT				543936
13	SEALING RING				543931
14	CRANKCASE GASKET				543933

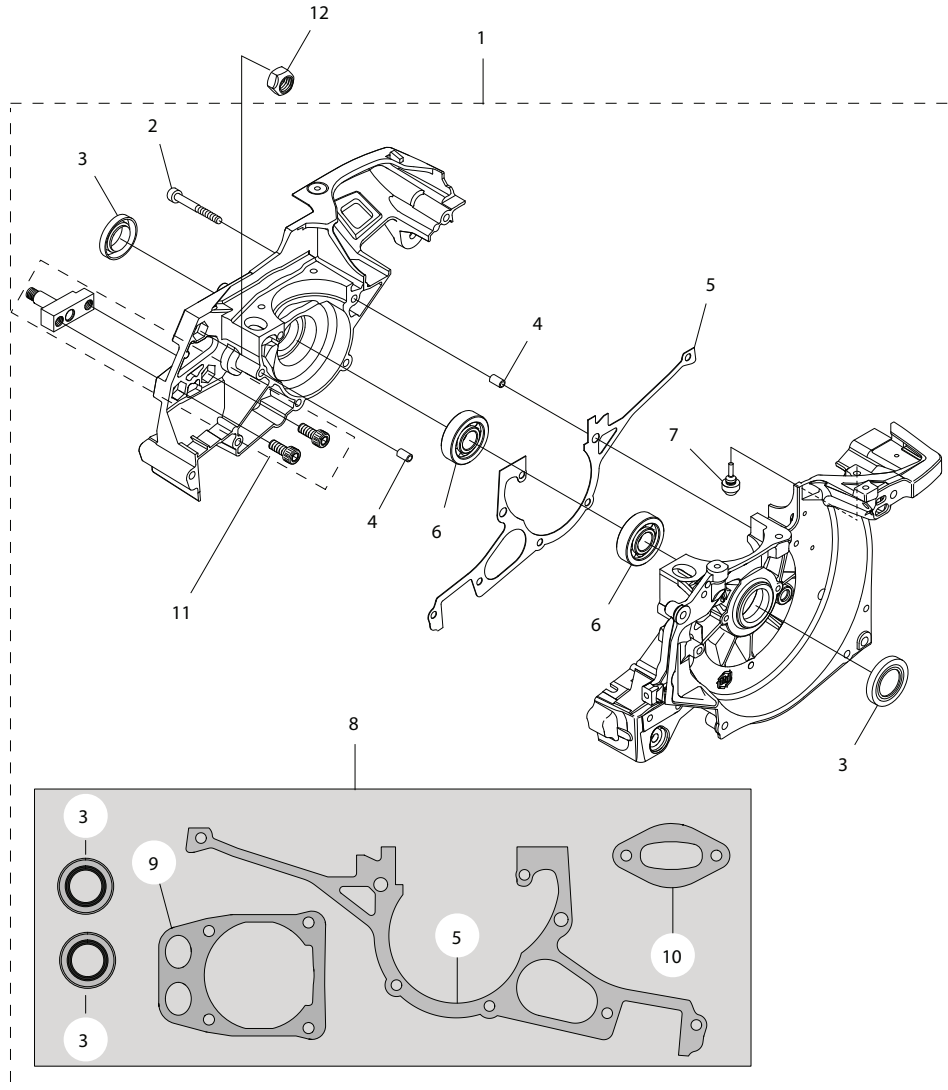

CRANKCASE ASSEMBLY

KEY	DESCRIPTION	TORQUE		LOCTITE® 242	PART NUMBER
		Nm	in-lbs.		
1	CRANKCASE ASSEMBLY				543929
2	CRANKCASE SCREW	12 - 14	106 - 124	x	543930
3	SEALING RING				543931
4	GUIDE PIN				543932
5	CRANKCASE GASKET				543933
6	MAIN BEARING				543934
7	RUBBER BUSHING				543935
8	GASKET KIT				543936
9	CYLINDER BASE GASKET				543937
10	MUFFLER GASKET				543938
11	BAR STUD KIT			x	544129
12	BAR BRACKET NUT				543941

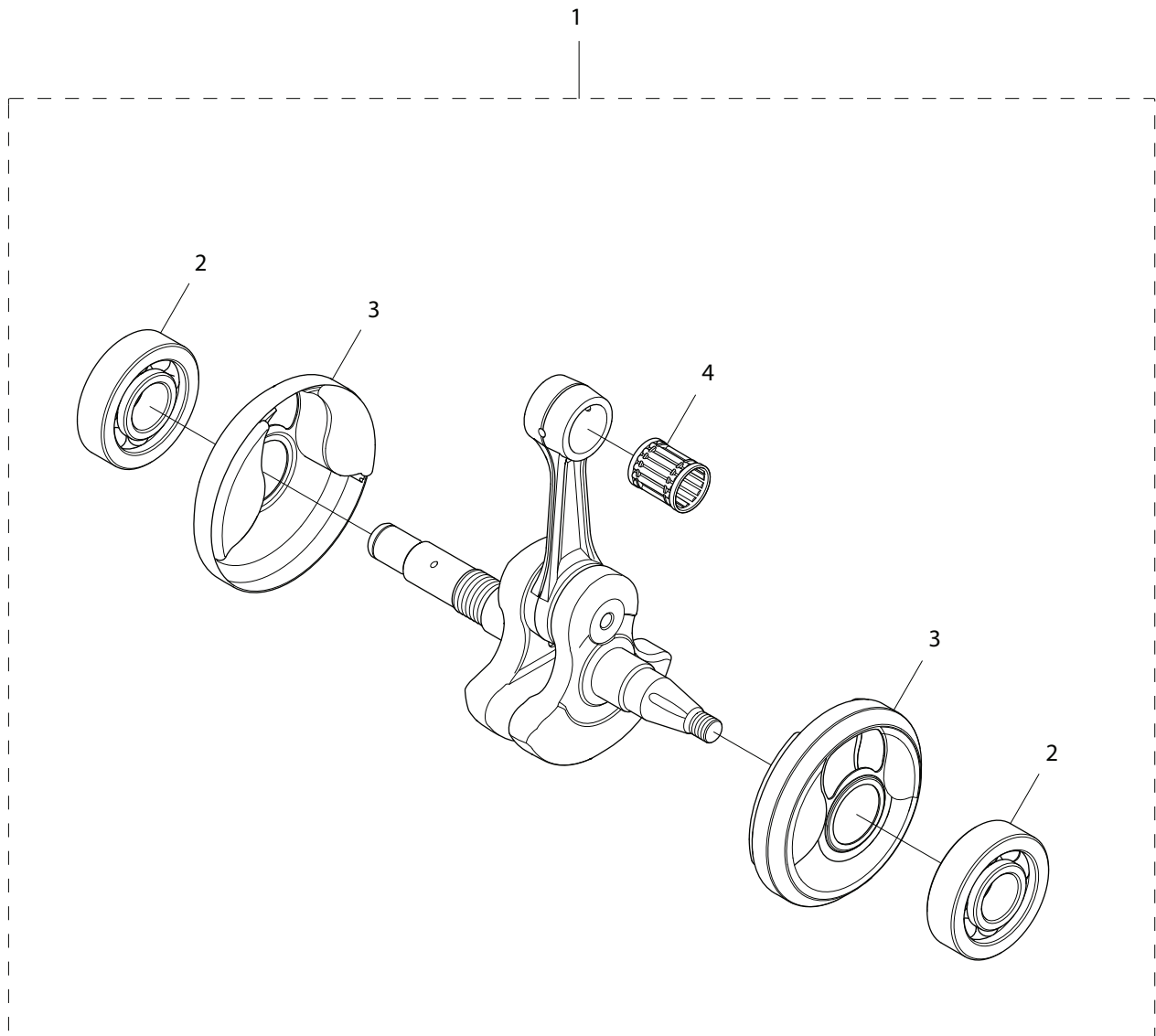

CRANKSHAFT ASSEMBLY

KEY	DESCRIPTION	TORQUE		LOCTITE® 242	PART NUMBER
		Nm	in-lbs.		
1	CRANKSHAFT ASSEMBLY				543952
2	MAIN BEARING				543934
3	CRANKSHAFT SHIELD				543953
4	NEEDLE BEARING				543949

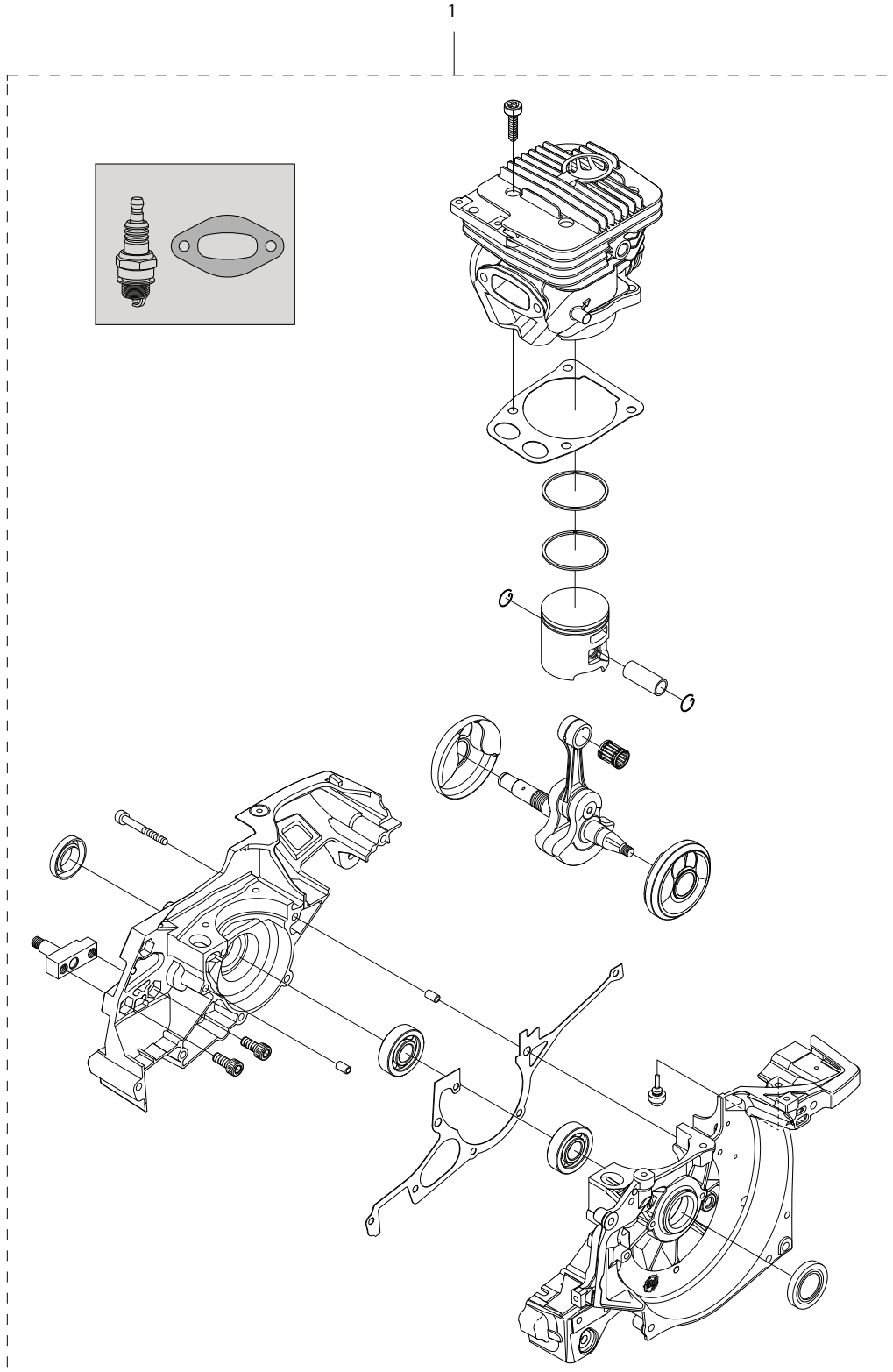

COMPLETE ENGINE ASSEMBLY

KEY	DESCRIPTION	TORQUE		LOCTITE® 242	PART NUMBER
		Nm	in-lbs.		
1	CRANKCASE W/PISTON & CYL COMPLETE				544121

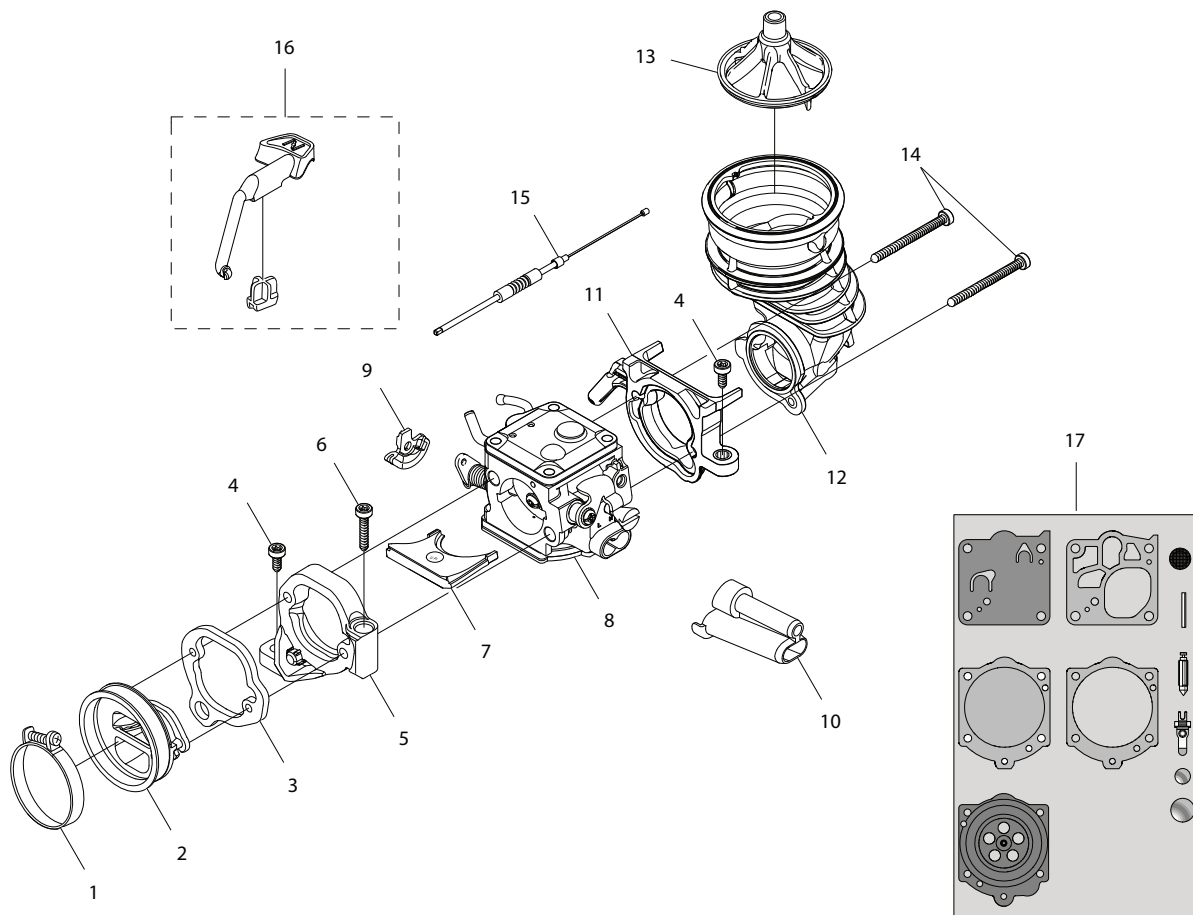

CARBURETOR & INTAKE ASSEMBLIES

KEY	DESCRIPTION	TORQUE		LOCTITE® 242	PART NUMBER
		Nm	in-lbs.		
1	INLET BOOT CLAMP				544069
2	INLET BOOT				544070
3	FLANGE				544071
4	FLANGE CLUTCH SIDE SCREW			x	544072
5	FLANGE BRACKET				544073
6	SCREW			x	544065
7	SEPARATOR PLATE				544074
8	CARBURETOR (WALBRO RWJ-5A)				544075
9	THROTTLE CABLE LEVER				544111
10	ADJUSTMENT GUIDE				544116
11	MANIFOLD BRACKET				544112
12	AIR INTAKE MANIFOLD				544113
13	AIR FILTER BRACKET				544114
14	CARBURETOR MOUNTING SCREW			x	544115
15	THROTTLE CABLE ASSEMBLY				543975
16	CHOKE LEVER				544117
17	CARBURETOR REPAIR KIT				544118

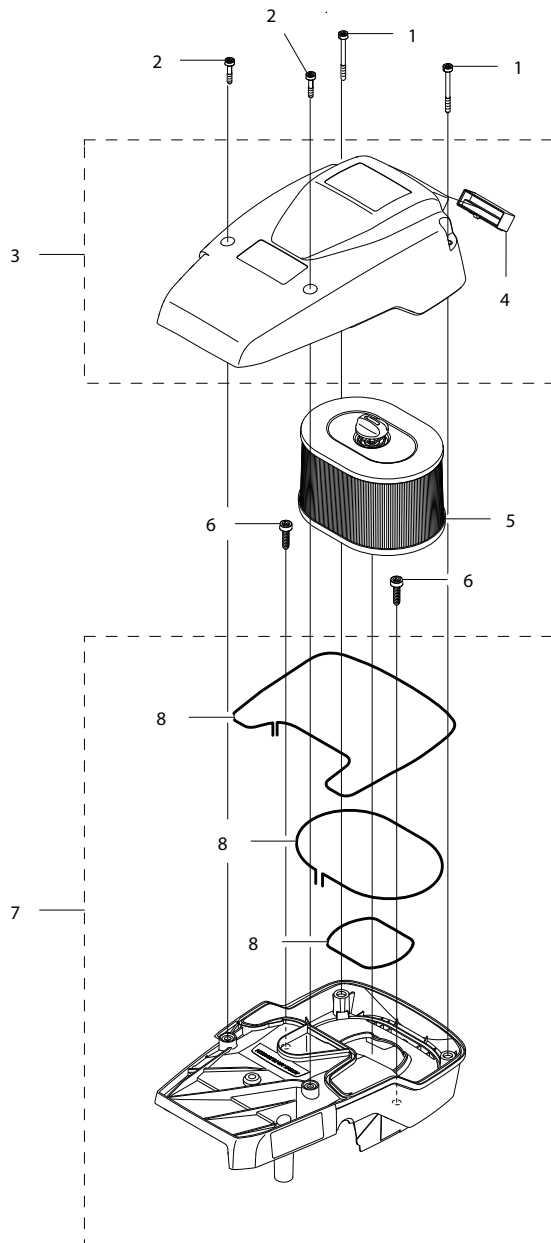

CYLINDER & AIR FILTER ASSEMBLIES

KEY	DESCRIPTION	TORQUE		LOCTITE® 242	PART NUMBER
		Nm	in-lbs.		
1	FILTER COVER REAR SCREW	3.5	31		544060
2	FILTER COVER FRONT SCREW	2	20		544061
3	FILTER COVER				544062
4	AIR INTAKE INSERT				544063
5	AIR FILTER				544064
6	CYLINDER COVER SCREW			x	544065
7	CYLINDER COVER ASSEMBLY				544066
8	CYLINDER COVER SEALS				544067

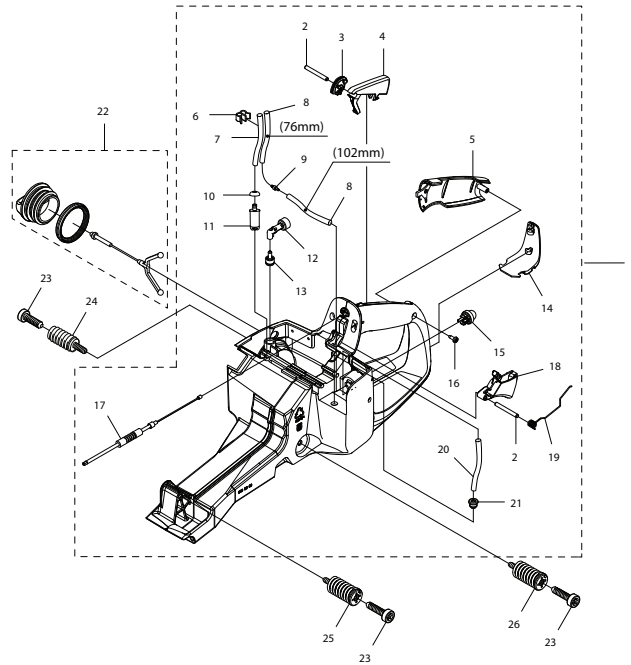

FUEL TANK ASSEMBLY

KEY	DESCRIPTION	TORQUE		LOCTITE® 242	PART NUMBER
		Nm	in-lbs.		
1	FUEL TANK ASSEMBLY				543812
2	PARALLEL PIN				543813
3	CABLE LEVER				543814
4	THROTTLE LOCK OUT LEVER				543815
5	REAR HANDLE COVER				543816
6	CLIP				543818
7	FUEL LINE				543993
8	CHECK VALVE TUBE				543994
9	CHECK VALVE				543969
10	HOSE CLAMP				543970
11	FUEL FILTER				543971
12	TANK VENT ASSEMBLY				544990
13	TANK VENT FITTING				544122
14	REAR HANDLE GROUND SUPPORT				543972
15	PURGE BULB				543973
16	REAR HANDLE SCREW				543974
17	THROTTLE CABLE ASSEMBLY				543975
18	THROTTLE TRIGGER				543976
19	TRIGGER SPRING				543977
20	PURGE BULB TUBE				543995
21	GROMMET				543978
22	GAS TANK CAP ASSEMBLY				543979
23	SHOCK ABSORBER SCREW			x	543981
24	SHOCK ABSORBER CLUTCH SIDE			x	543982
25	SHOCK ABSORBER FRONT			x	543983
26	SHOCK ABSORBER FLYWHEEL SIDE			x	543984

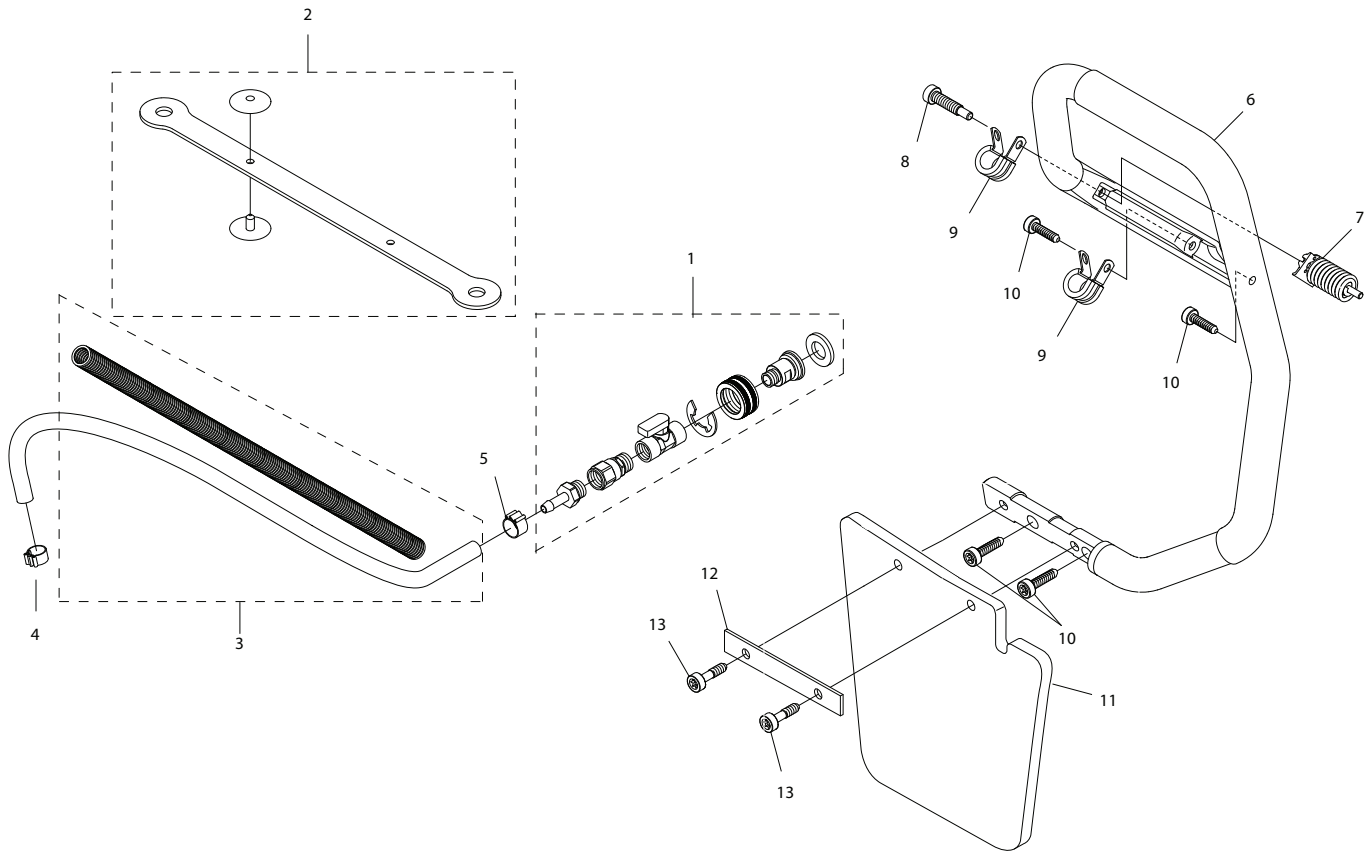

WATER DELIVERY SYSTEM

KEY	DESCRIPTION	TORQUE		LOCTITE® 242	PART NUMBER
		Nm	in-lbs.		
1	WATER HOSE VALVE ASSEMBLY				543996
2	HOSE HANGER				547969
3	WATER HOSE WITH PROTECTIVE COVERING				543999
4	CLAMP, WATER HOSE TUBE SIDE				544000
5	CLAMP, WATER HOSE VALVE SIDE				544001
6	FRONT HANDLE				544002
7	SHOCK ABSORBER, FRONT HANDLE				544003
8	SCREW, SHOCK ABSORBERS			x	543981
9	CLIP, FRONT HANDLE				544008
10	SCREW, FRONT HANDLE			x	544009
11	GUARD FLAP				544010
12	BACKING PLATE, GUARD FLAP				544011
13	SCREW, GUARD FLAP			x	544012

5. This section covers the removal, inspection, and assembly of the air intake.**5.1**

Loosen the air filter cover screws and remove the air filter cover.

**5.2**

Loosen air filter screw.

- Inspect air filter for dirt or damage.
- Replace with P/N 544064.



6. This section covers the removal, inspection and installation of the spark plug.**6.1**

Remove the spark plug cap.

**6.2**

Remove the spark plug.

**6.3**

Inspect spark plug.

- If it's dirty, clean with a wire brush.
- Replace spark plug if fouled or eroded. USE NGK BRMR7A or Champion RCJ6Y.



6.4

Gap if necessary to 0.20" (0.5mm).



6.5

Assemble in reverse order ensuring that the spark plug is properly engaged in threads and fully seated.



7. This section covers side cover removal, side cover nut removal, inspection and assembly.**7.1**

Loosen side cover nut.

- Remove side cover.
- Remove tensioner plate screws and tensioner plate.

**7.2**

Remove tensioner assembly.

Note the orientation of the tensioner assembly.

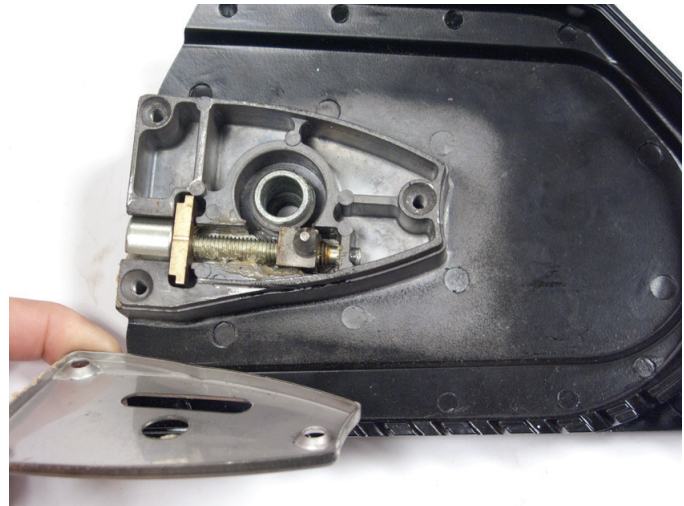
**7.3**

Inspect tensioner and replace if needed.

- Clean tensioner threads and liberally apply grease to threads prior to assembly.

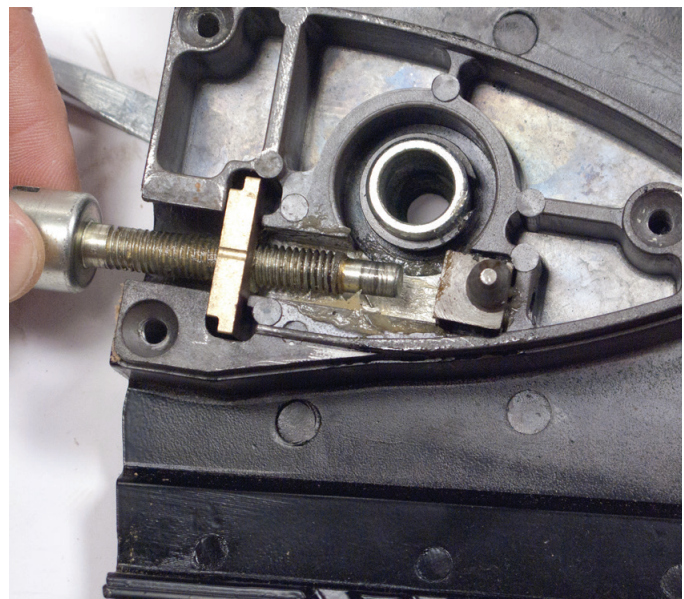

7.4

Inspect side cover, nut and circlip.
Replace if damaged.

Circlip can be removed with a large
flathead screwdriver.



7.5

Assemble in reverse order.



8. This section covers clutch removal, rim sprocket removal, inspection and assembly. Refer to sections 5 and 6 if necessary.

Rim sprocket removal procedure.

8.1

Using flat head screwdriver, remove retaining ring.

* Use caution when removing retaining ring to prevent damage to the split retainer or crankshaft.

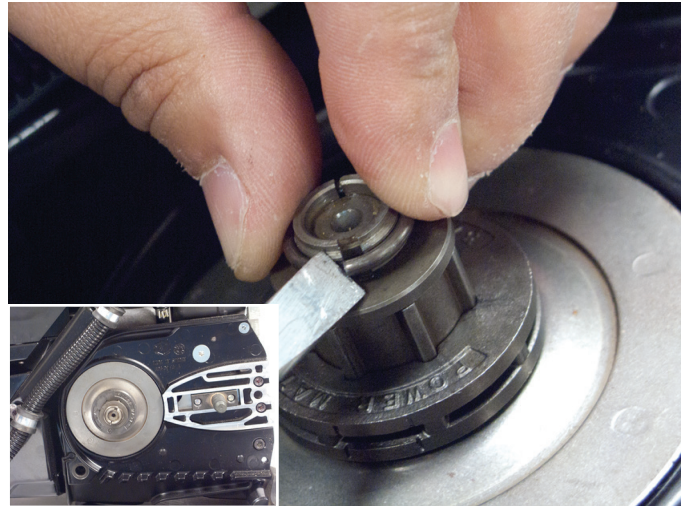

8.2

Remove the split retainer and spacer.

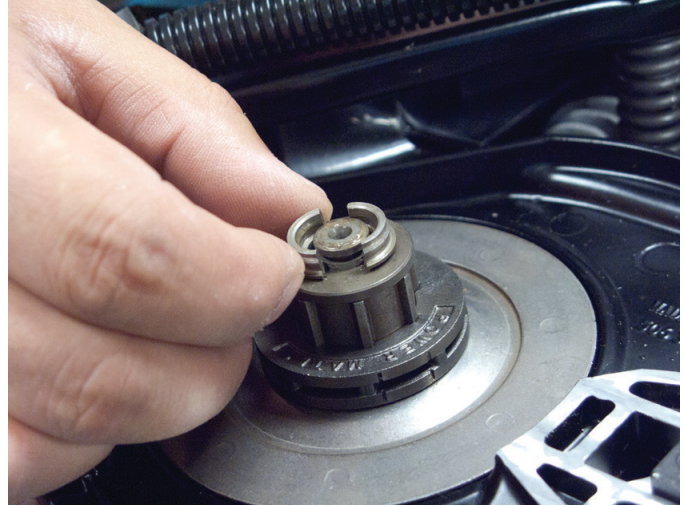

8.3

Inspect rim sprocket and replace if necessary (P/N 70949).

- Replace if the rim sprocket teeth are worn to points as shown on right.

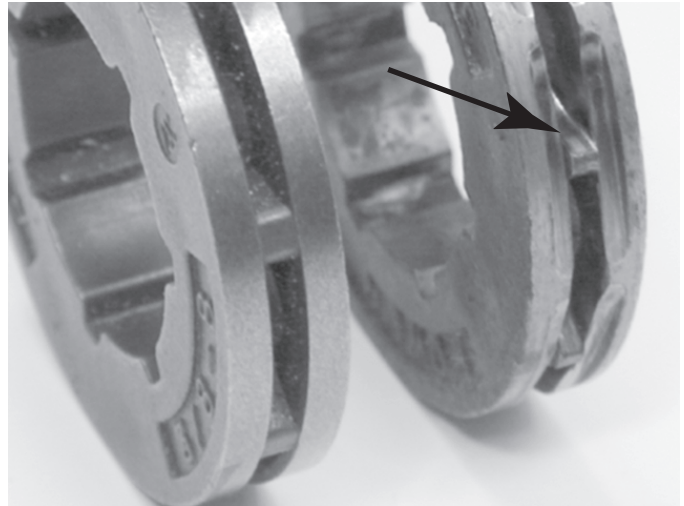

8.4

Rim sprocket assembly.

- Assemble in reverse order.



8.5

Remove clutch cup and needle bearing.

- Apply grease to needle bearing prior to reinstalling.

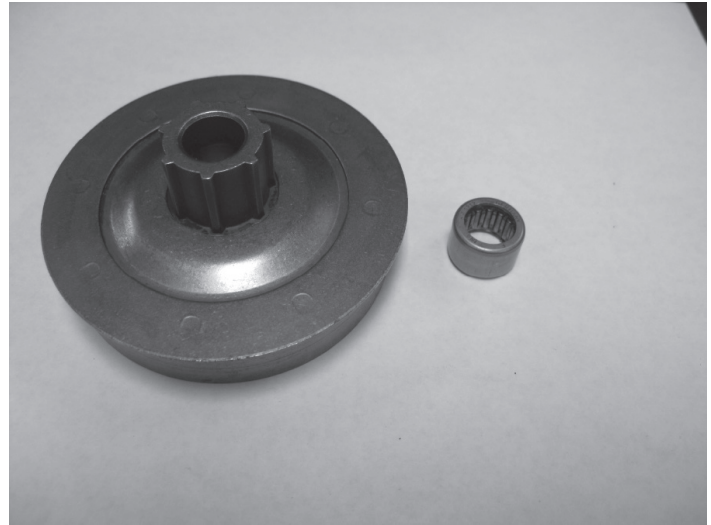

8.6

Clutch removal.

- Remove clutch cup & rim sprocket first.

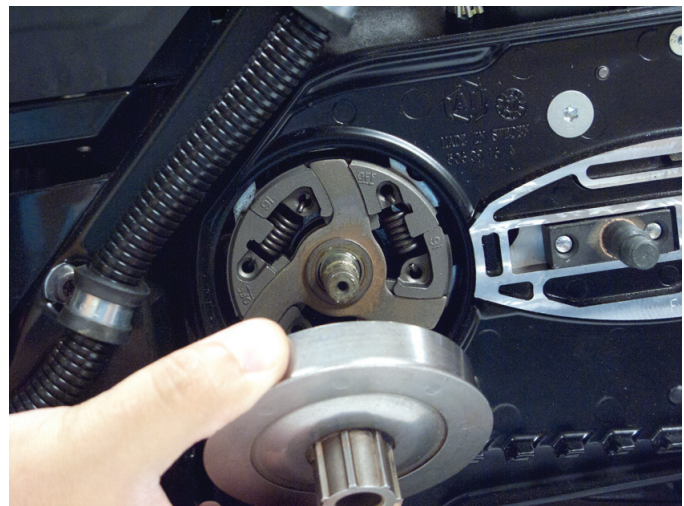

8.7

Insert piston stop tool into spark plug hole.



8.8

Remove clutch with clutch tool (P/N 546659).

- Rotate clockwise to remove clutch (clutch is left-handed thread).

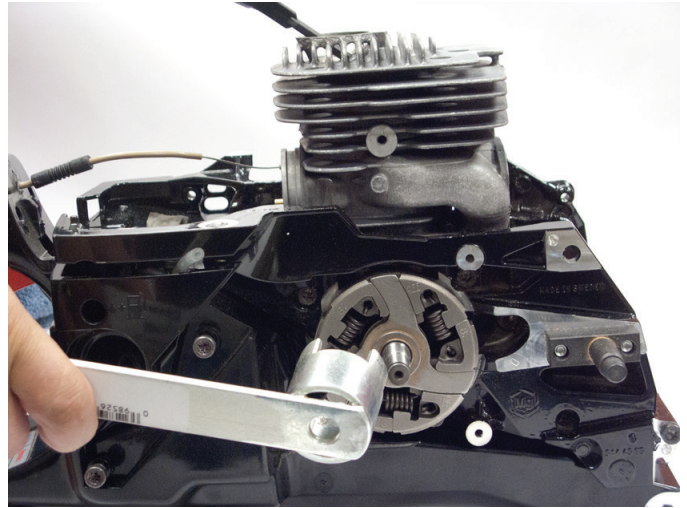

8.9

Clutch is marked with arrow (off) for direction of removal.



8.10

Inspect clutch shoes (P/N 543927) for excessive wear or damage.

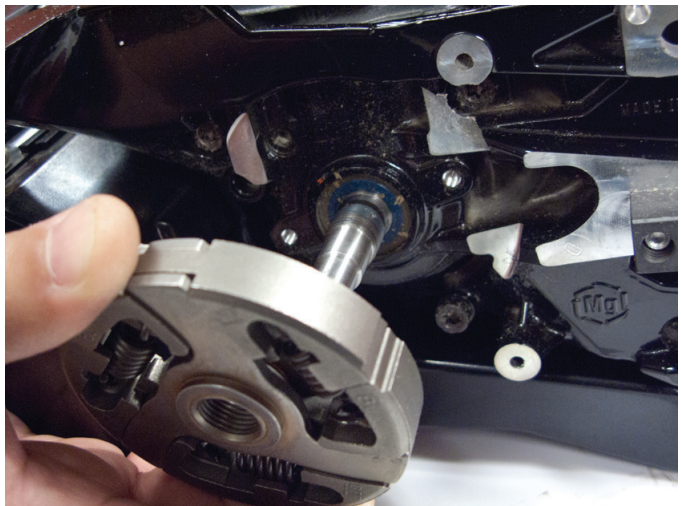

8.12
Height of clutch shoes should not be less than 1 mm.

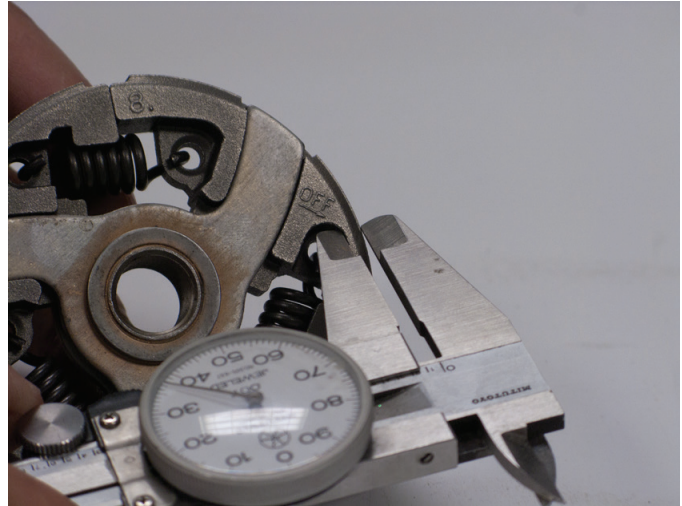

8.12
Inspect and clean springs if necessary.



8.13

Remove the springs.

- Set into a vice to hold in place.
 - Place a flat head screwdriver or flat tipped rod against the spring hook.
 - Tap lightly at the end of the screwdriver or rod. This will cause the spring hook to detach.
-
- Push the spring out.
 - Repeat with the remaining two springs.

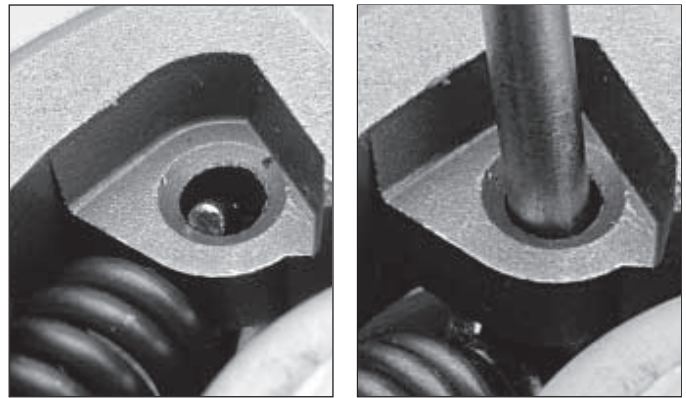
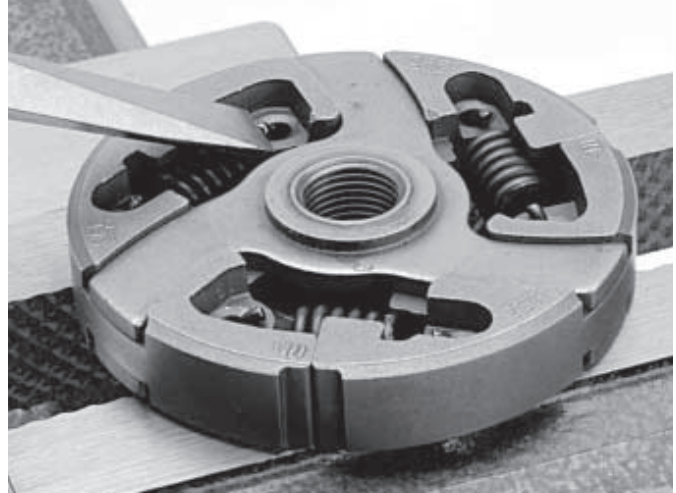

8.14

Fit clutch shoes.

- Slide the spring into the narrower section of the clutch shoe first.

NOTE: All spring hooks should point the same direction as the word "OFF". See illustration at right for an example.

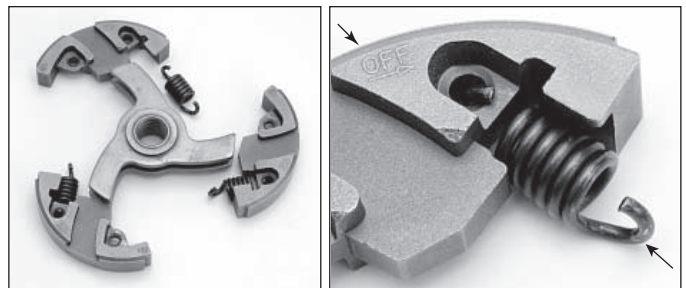

8.15

Fit springs.

- Turn the clutch so the word "OFF" is facing down.
- Push the spring hook into its hole by using a pointed tool.

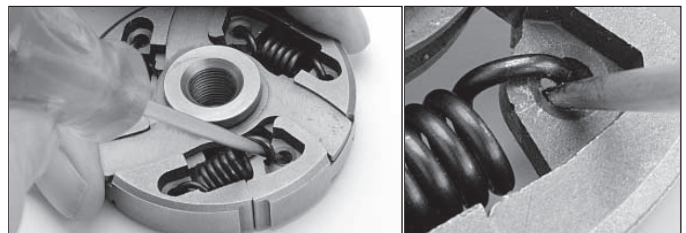

9. This section covers the removal of the starter cover, replacement of the starter rope and replacement of the recoil spring.

9.1

Loosen (4) starter cover screws.



9.2

Remove starter cover from saw.

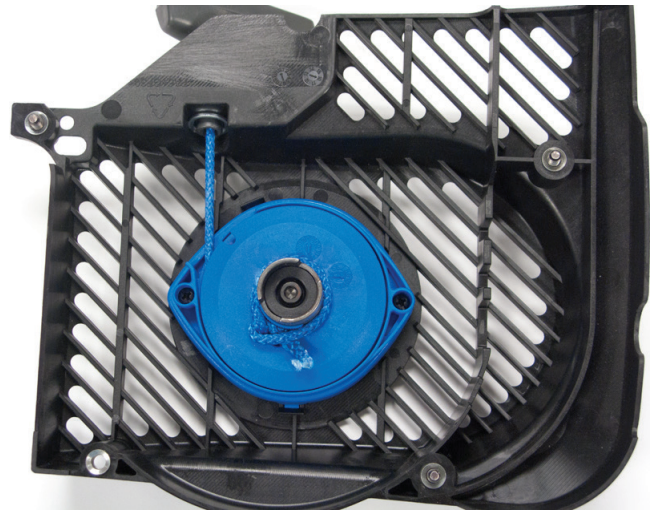

9.3

Relieve spring tension in starter recoil.

- Pull 6 - 8 in (15 - 20 cm) of rope out.
- Line up rope with notch in pulley.

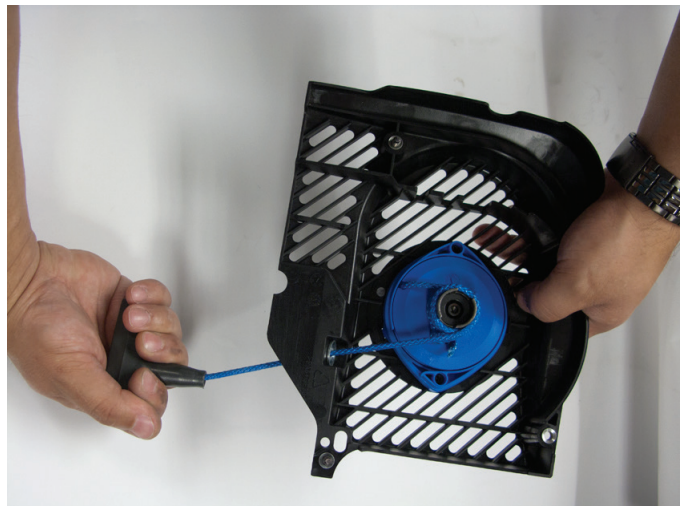

9.4

Rotate pulley shaft counter clockwise, allowing pulley to unwind using rope as a brake.



9.5

Pulley removal from spring.

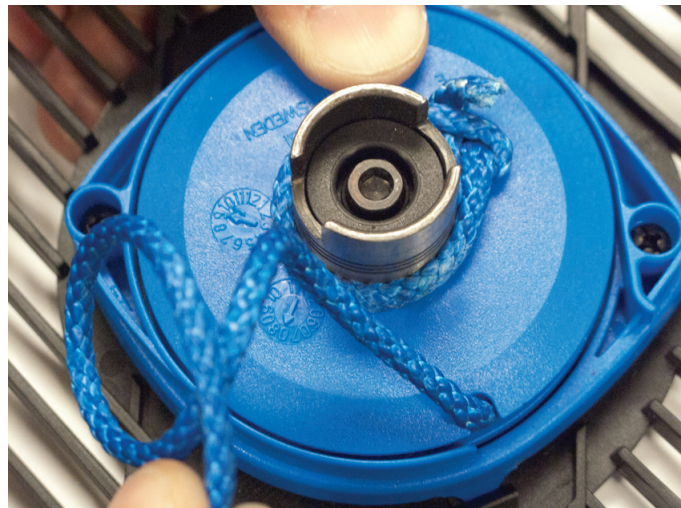

9.6

Remove the center screw and components.

Note the orientation of the parts.

refer to photo (9.7).



9.7

Note the orientation of the parts for re-installation.



9.8

A. Lift pulley from spring housing.
NOTE: the spring catch and spring hook must be aligned during installation (arrows).

B. Remove the two screws holding the spring housing.

C. Use CAUTION when removing the spring to prevent the spring from unwinding.

D. Inspect spring and lubricate with light oil.

E. Align notch in spring housing with end of spring.

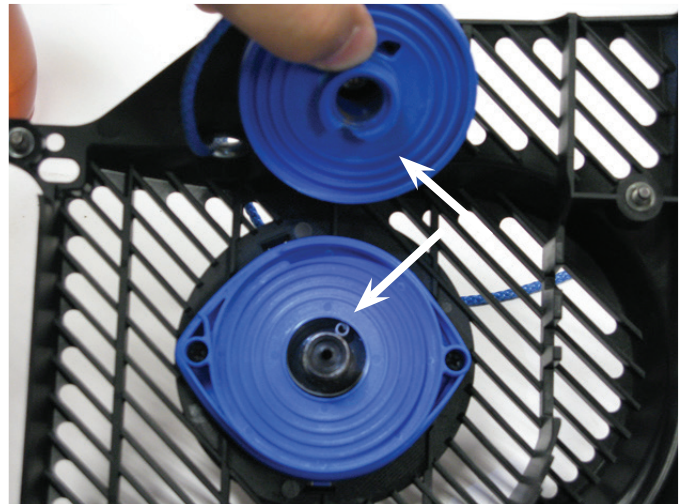

9.9

Inspect rope (P/N 544023) and pulley (P/N 544127). Replace if necessary. Note the orientation of the knot.



9.10

Assemble in reverse order.



9.11

Install the center screw and components. Note the orientation of the parts for re-installation. See 9.7 for orientation.

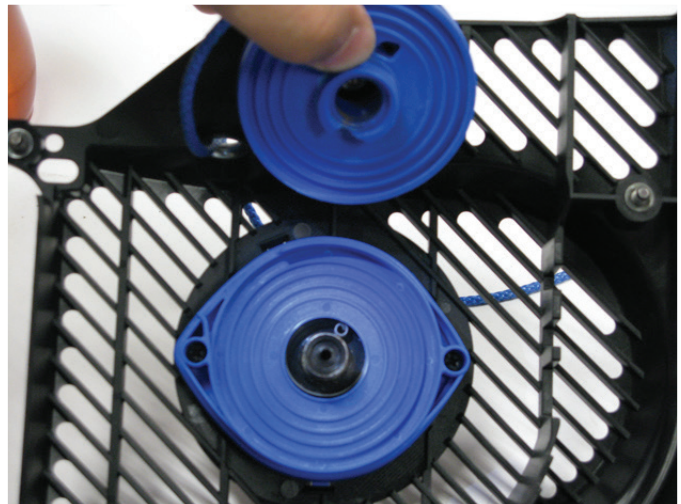

9.12

Tension pulley.

- Wind rope onto pulley clockwise, leaving 6-8 in (15 - 20 cm) of rope out.
- Ensure the pulley spring catch is installed on the spring hook.

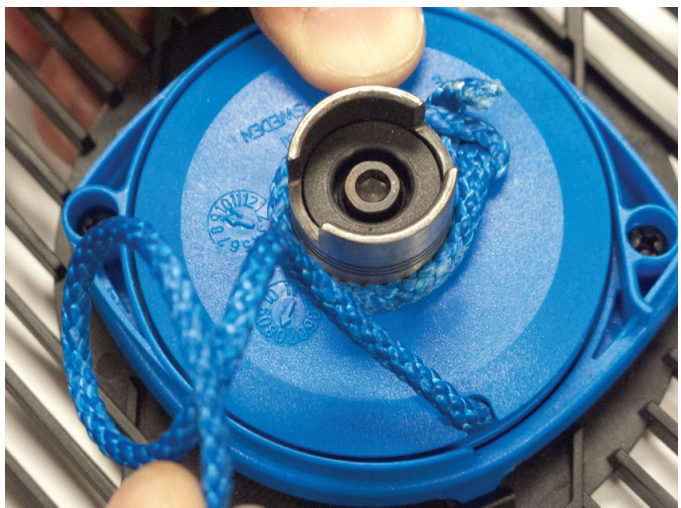

9.13

Insert the rope into the pulley notch.

- Wind rope clockwise around pulley shaft 3 - 4 times. Then pull starter rope handle.
- Repeat as necessary to ensure proper spring tension.
- Ensure with starter rope fully extended the pulley can still be rotated an additional 1/2-turn before being stopped by the spring.



9.14

- Rope must fully retract into starter cover.

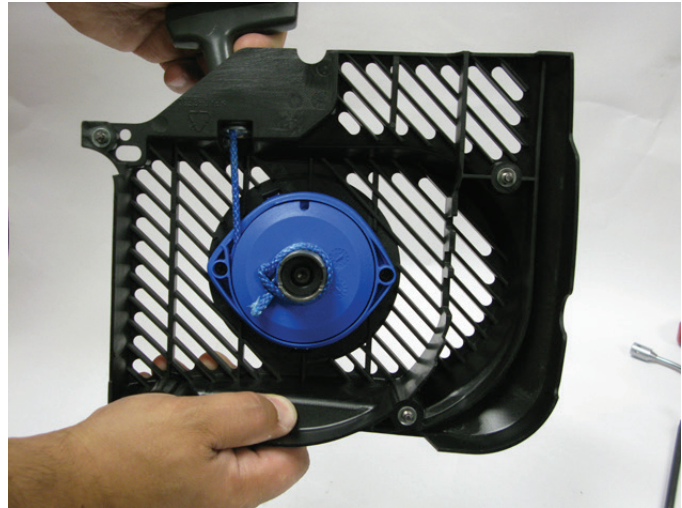

9.15

Install starter cover.

- Pull starter rope to engage starter pawls and seat cover.
- Tighten side cover screws.



10. This section covers the removal & replacement of the carburetor & cylinder cover. Removal of air intake components and front handle is required. Refer to sections 5 & 15 if necessary.

10.1

Remove air filter cover and air filter.
Refer to section 5.

Remove (2) screws (P/N 544065).

Lift cylinder cover off from the front of the cover.

Install in reverse order using Loctite® 242



10.2

Carburetor Removal.

Remove choke lever (P/N 544117).

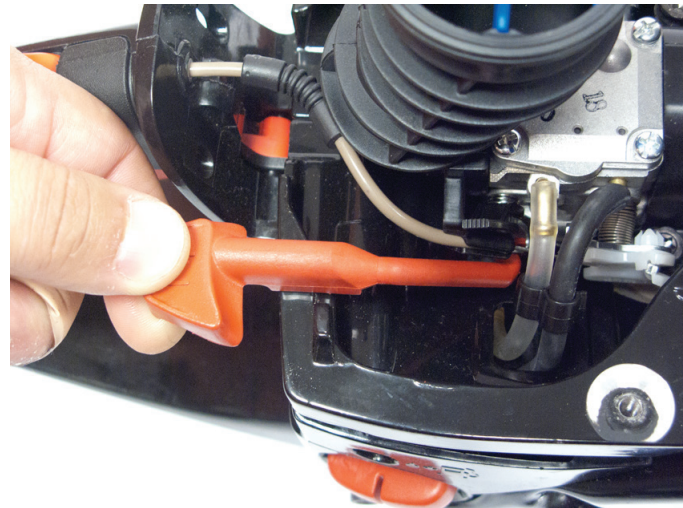

10.3

Lift up choke lever and rotate 90 degrees then pull out from carburetor.

Install in reverse order.

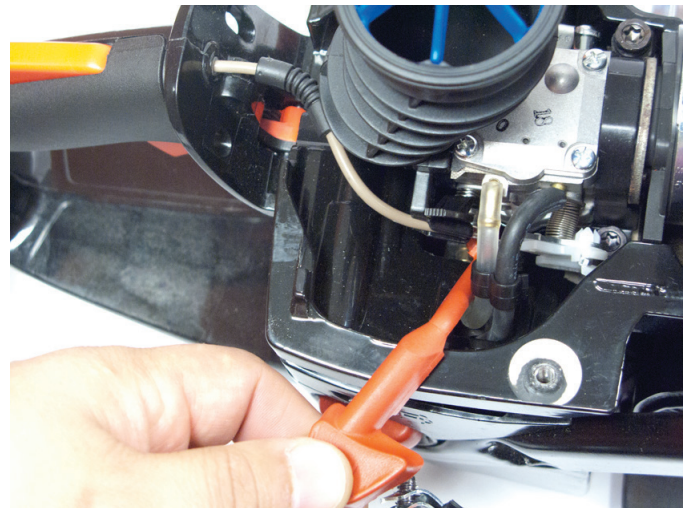

10.4

Remove (2) carburetor mounting screws (P/N 544115) using a Workshop Key Torx T27 (P/N 546191).

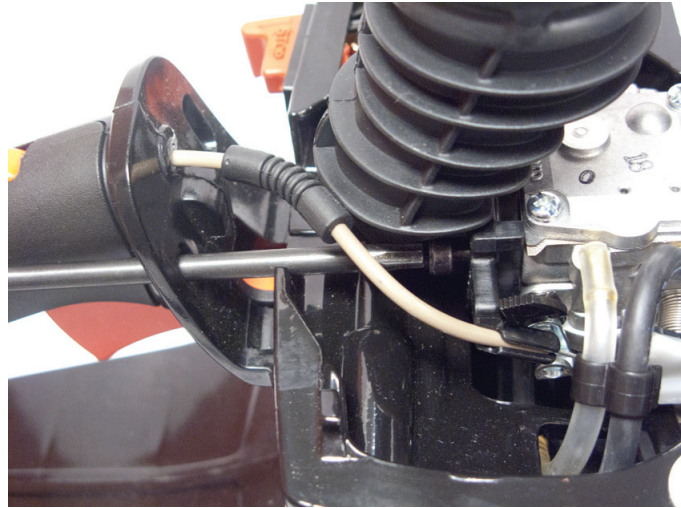

10.5

Remove bracket screw (P/N 544072).

Remove air intake manifold (P/N 544113).

Inspect for damage.

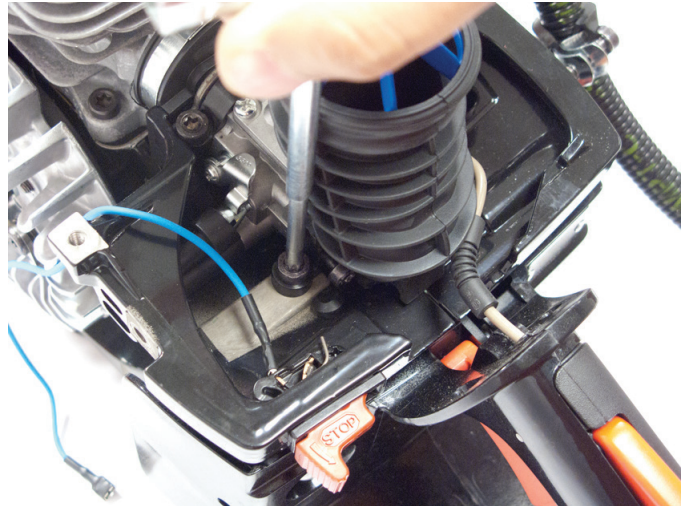

10.6

Remove fuel line, check valve tube and carburetor.

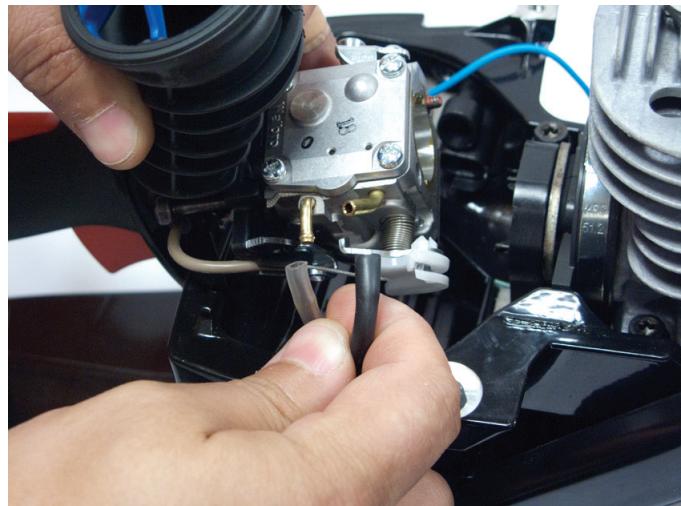

10.7
Remove throttle cable from carburetor.

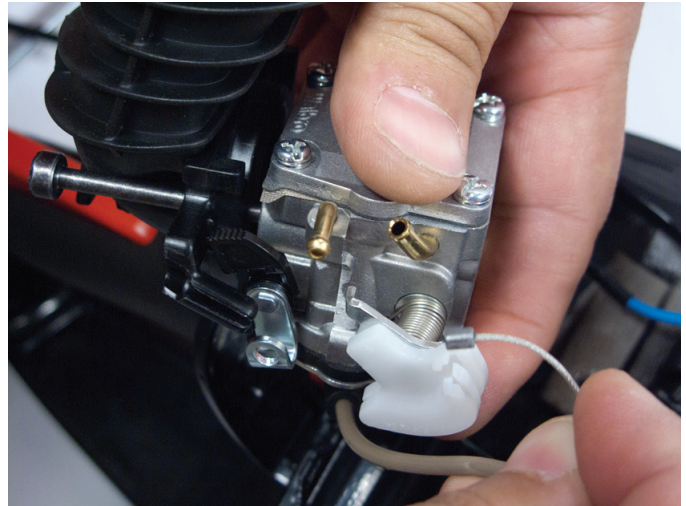
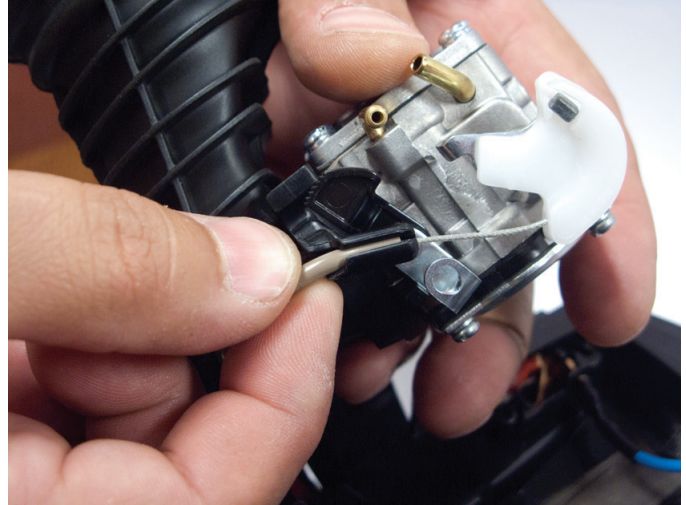

10.8
Remove clutchside flange screw (P/N 544072) and screw (P/N 544065).

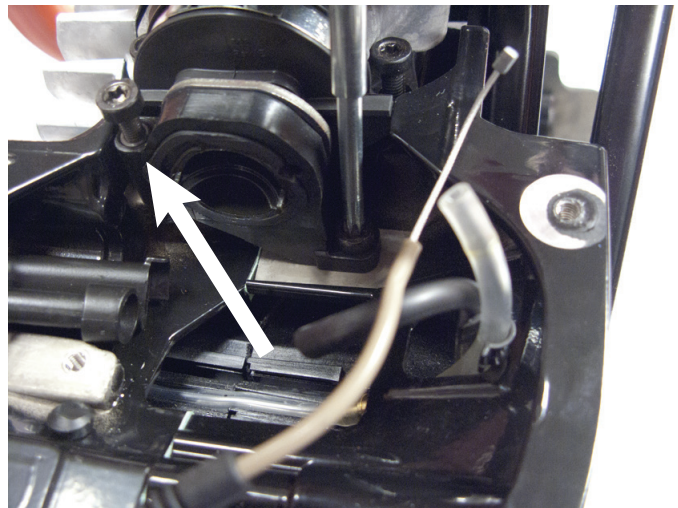

10.9

Remove plate from inlet boot.

Remove the flange bracket and flange from the inlet boot.

Note orientation of plate "UP".

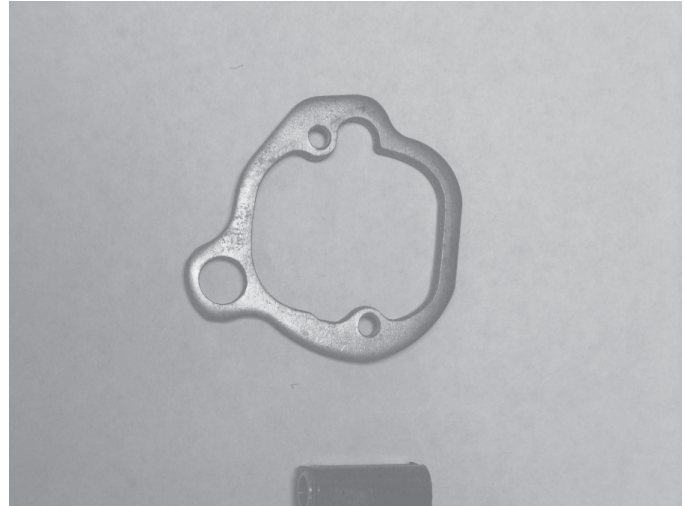

10.10

Loosen clamp.

Inspect and replace inlet boot if damaged (see section 16.2).

- Cylinder must be loosened in order to remove the inlet boot.
- Install in reverse order.
- Using Loctite® 242 for screws.
- Note orientation of plate "UP".



11. This section covers the removal, inspection and assembly of the muffler. Removal of WallWalker® and cylinder cover is required. Refer to section 10 if necessary.

11.1

Muffler removal.

- Remove (2) cylinder/muffler screws (P/N 543942) with srench.
- Remove (1) lower muffler mounting screw (P/N 543846) and muffler mounting washer (P/N 543847).



11.2

Inspect and replace if damaged.

- Muffler (P/N 543845).
- Muffler gasket (P/N 543938).
- Heat Deflector (P/N 543844).

Reassemble in reverse order using Loctite® 242.



12. This section covers the removal, inspection and installation of the guide bar stud. Removal of WallWalker® and muffler is required. Refer to section 10 if necessary.

12.1

Bar stud removal (P/N 544129).

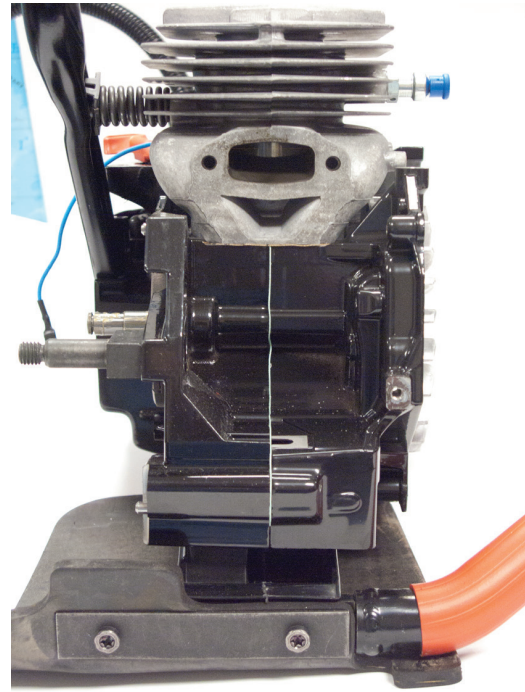

12.2

Using a 6 mm allen or hex head, remove (2) bolts holding bar stud.

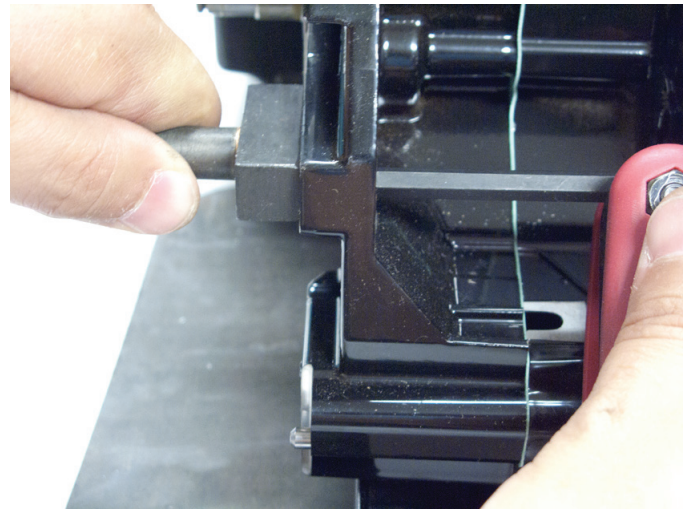

12.3

Inspect bar stud (P/N 544129).

- Replace if damaged.
- Install in reverse order using Loctite®242.



13. This section covers the removal, inspection and installation of the ignition module. Removal of the starter is required. Refer to section 8 if necessary.

13.1

- Remove starter cover.
- Remove starter cover shield.
- Disconnect the stop switch cable.
- Inspect and replace if damaged (P/N 544032).

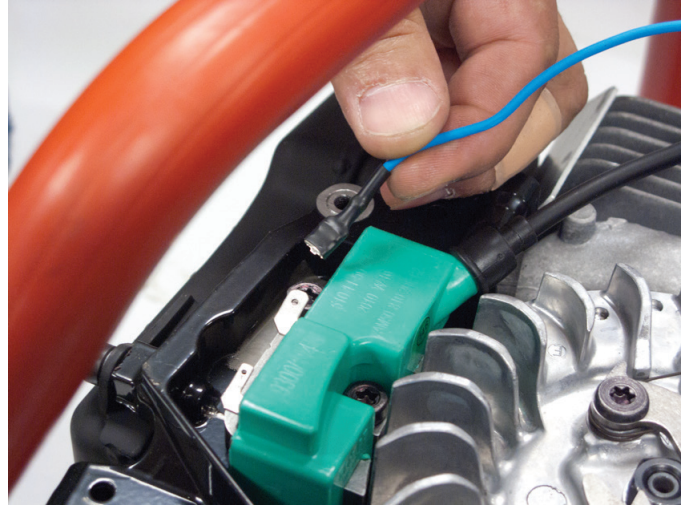

13.2

- Remove (2) ignition module screws (P/N 544038).
- Remove ignition module (P/N 544036).
- Inspect and replace if damaged.

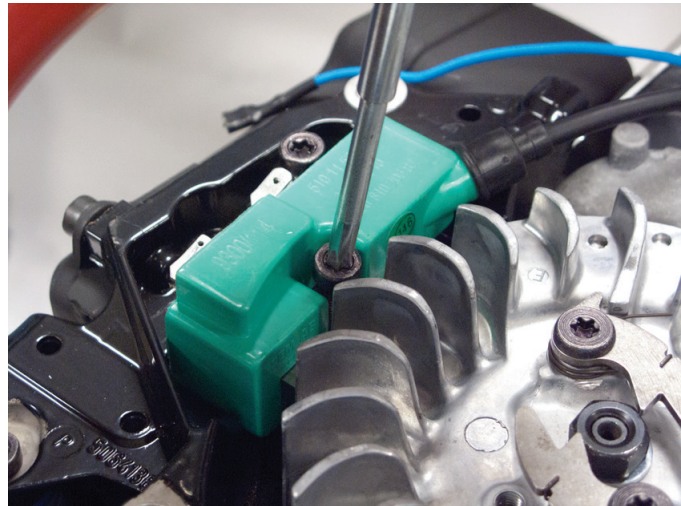

13.3

Reassemble in reverse order.

Place air gap gauge (.010 in/0.3 mm) on the magnet side of the flywheel.

- Set ignition module in place.
- Install ignition module screws with blue Loctite® 242.
- Holding gauge, rotate flywheel magnets around to coil.
- Torque ignition coil screws to 89-105 in/lbs (10 - 12 Nm).
- Remove gauge, rotate flywheel and check for clearance.
- Connect stop switch cable.

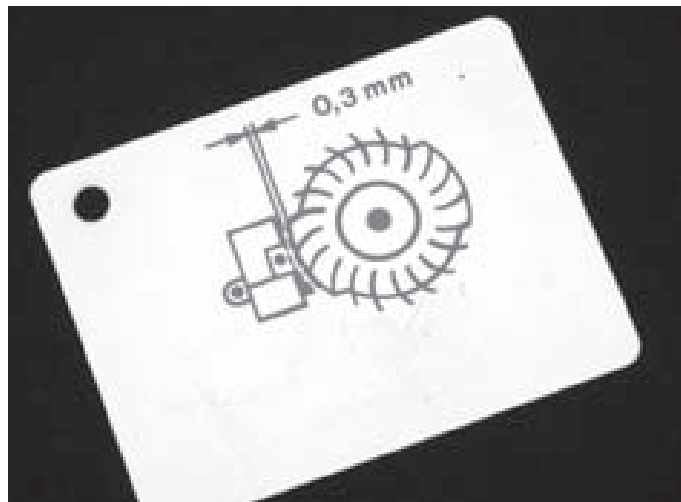

14.1

Remove stop switch (P/N 544031).

Disconnect cable wire.



14.2

Remove screw (P/N 544030).



14.3

Pry the switch to the left using the screwdriver.

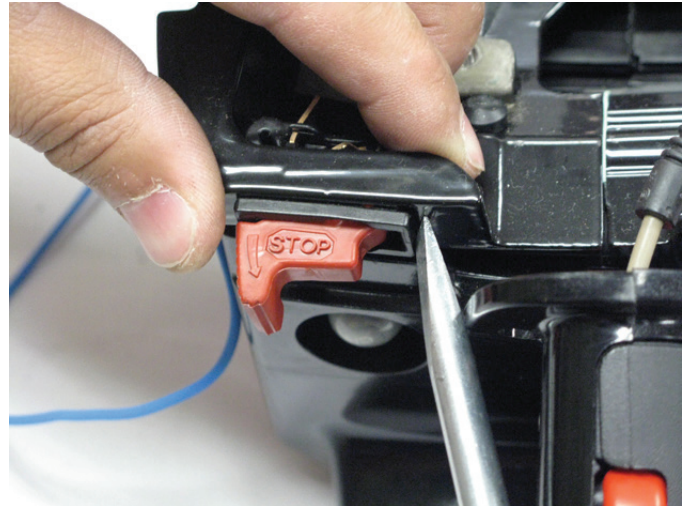

14.4

Pull the right side out first.

- Replace switch if damaged.
- Install in reverse order.
- Switch will snap back into place.
- Use Loctite®242 only on screw.



15. This section covers water hose and water tank cap.**15.1**

Inspect hose (P/N 543999), water pipe (P/N 543915) and water valve (P/N 543996).

Replace if damaged.

**15.2**

Release clip from water inlet pipe.
Pull hose upward.

Inspect hose and water inlet pipe,
replace if damaged.



16. This section covers the removal, inspection and assembly of the cylinder, piston and related components. Refer to section 5 & 10 if necessary

16.1

Remove outer shock absorber screw (set aside for reassembly) (P/N 543981).

Loosen (4) cylinder screws(P/N 543942).

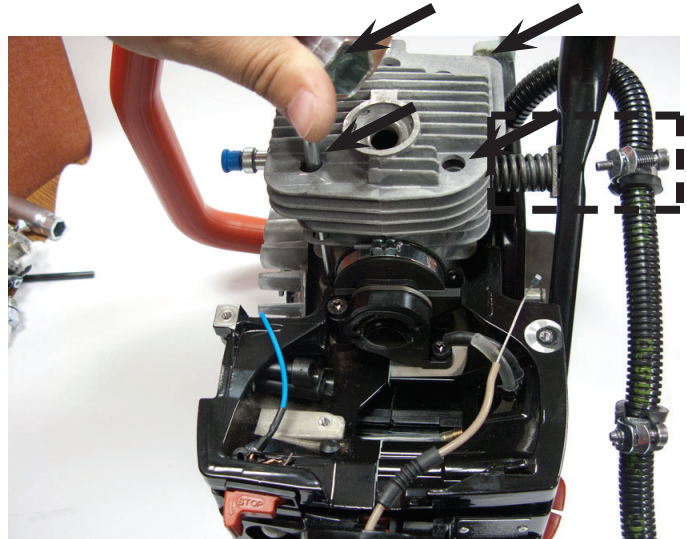

16.2

Remove cylinder from piston.

Remove shock absorber screw (see section 16.1).

Remove inlet boot and clamp. Set aside shock absorber, boot & clamp for reassembly later (see section 10.9).

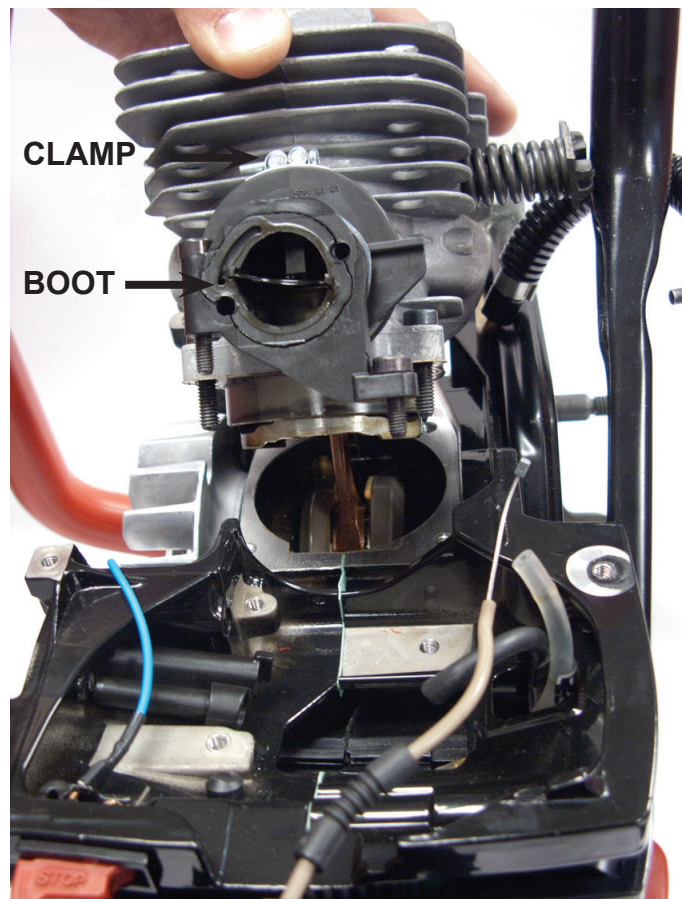

16.3

Remove wrist pin clip from each side of piston.



16.4

Remove wrist pin using the wrist pin punch (P/N 543196).

Remove piston and cylinder base gasket.



16.5

Clean crankcase.

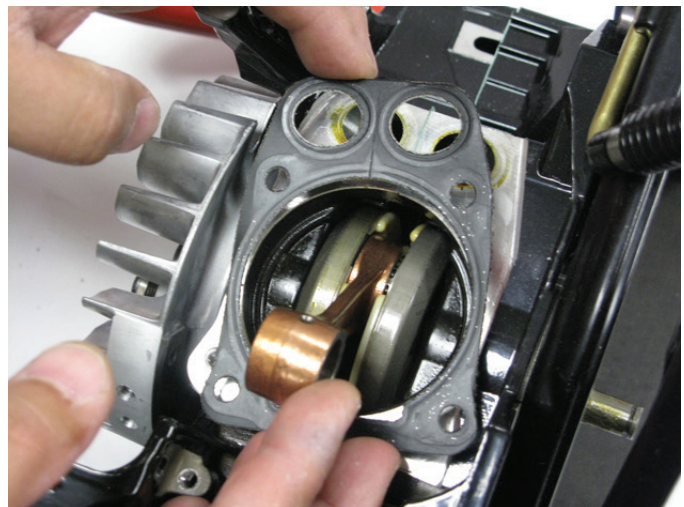

16.6
Inspect cylinder and piston (P/N 543843)
replace if damaged.



16.7
Install piston rings.
Install lower piston ring first.



16.8
Note the ring locator pins.



16.9

Note ring orientation.

*If rings are installed upside down or incorrectly, ring will not seat properly and piston damage will occur.

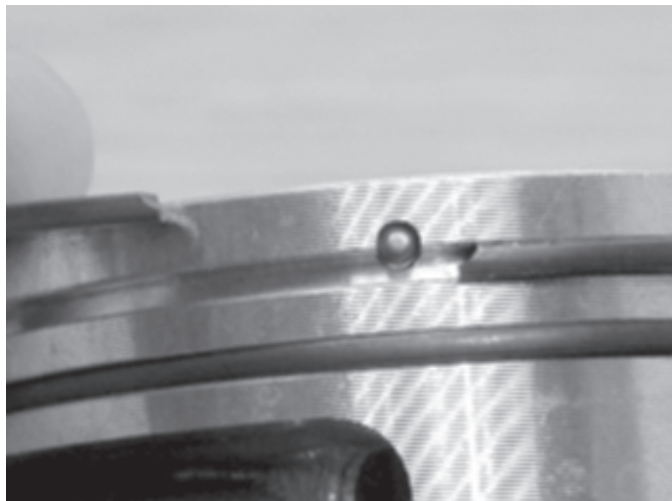

16.10

Lubricate crankcase gasket mating surface with ICS® 2-stroke oil.

Install cylinder base gasket.

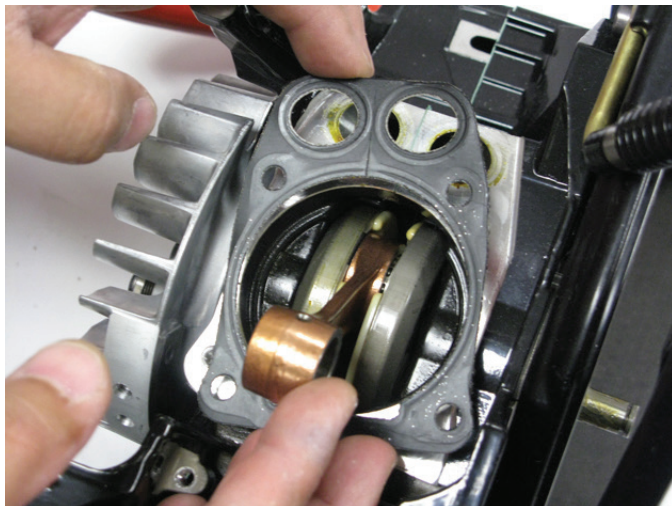

16.11

Lubricate needle roller with ICS® 2-stroke oil. Insert into the connecting rod.



16.12

Lubricate wrist pin with ICS® 2-stroke oil and partially install in the piston.

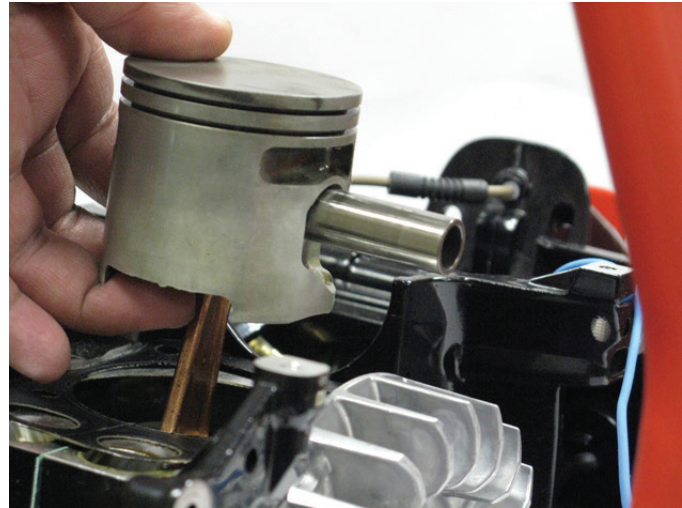

16.13

Install wrist pin clip into opposite side of the piston.

Make sure wrist pin clip is in the proper orientation.

See 16.15



16.14

Align the piston in correct orientation. Arrow on top of the piston points towards the muffler/exhaust port.

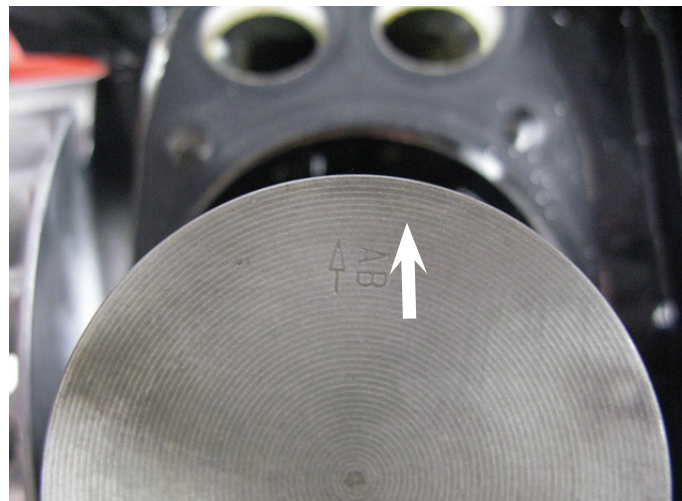

16.15

Install piston.

- A.) Align wrist pin with wrist pin needle bearing.
- B.) Complete wrist pin installation.
- C.) Install second wrist pin clip (note the orientation of the pin clips).
- D.) Coat piston with ICS® 2-stroke oil.

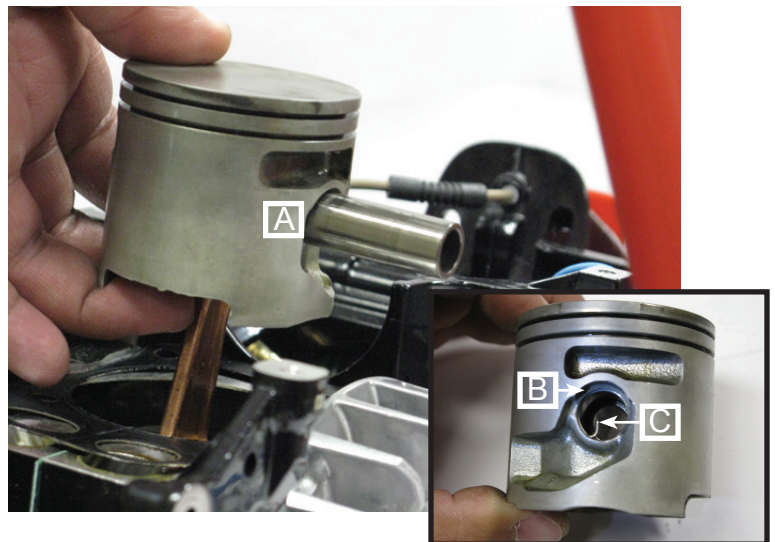

16.16

Install the inlet boot clamp, flange bracket, flange and shock absorber screw before cylinder installation.

- A.) Lubricate the cylinder bore with ICS® 2-stroke oil.
- B.) Compress the rings with compression tool (P/N 71543).
- C.) Slide cylinder onto piston, pushing ring tool down.
- D.) Remove ring compressor.
- E.) Slide cylinder onto piston and into the crankcase.
- F.) Align cylinder bolt holes with crankcase. Align cylinder screw with holes on gasket & crankcase.

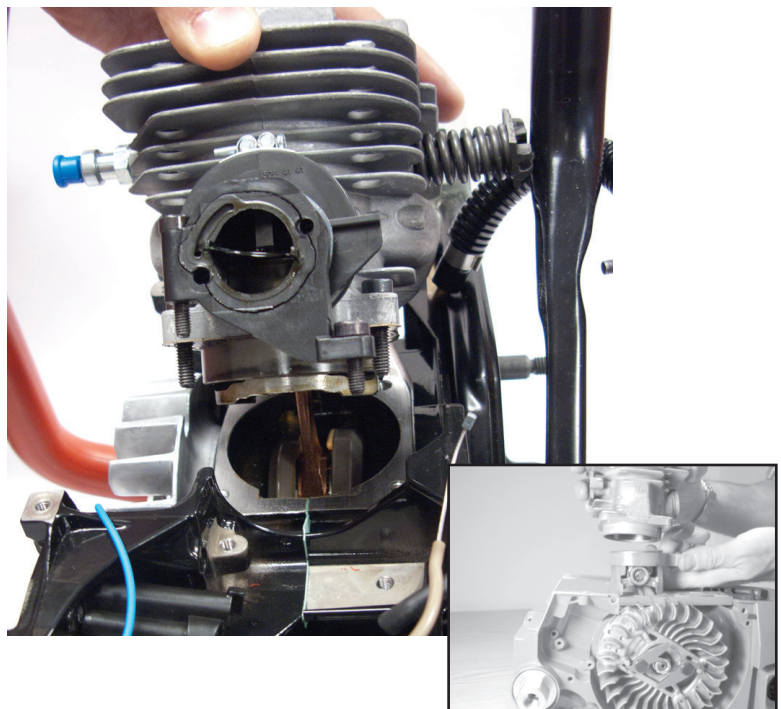

16.17

Install (4) cylinder screws using Loctite®242. Torque to 132-156 in-lbs (15 - 18 Nm).

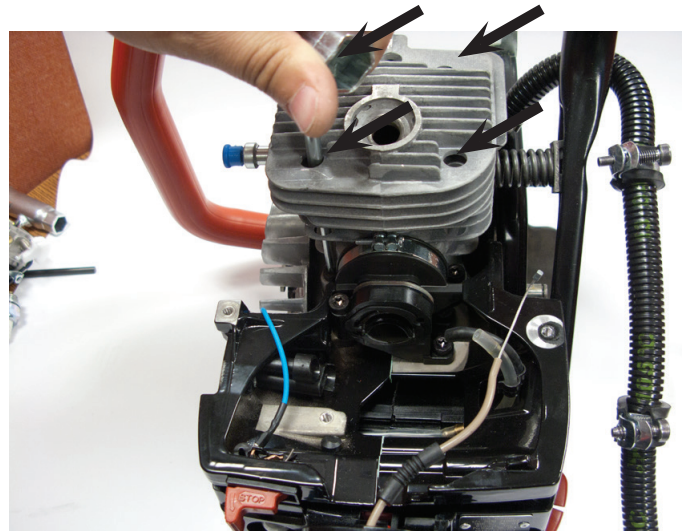

17. This section covers the removal, inspection and installation of the bottom guard and front handle.

17.1

Remove (2) screws (P/N 544012) and guard flap backing plate (P/N 544011).

Inspect guard flap for damage (P/N 544010) replace if damaged.

Reassemble in reverse order using Loctite®242.

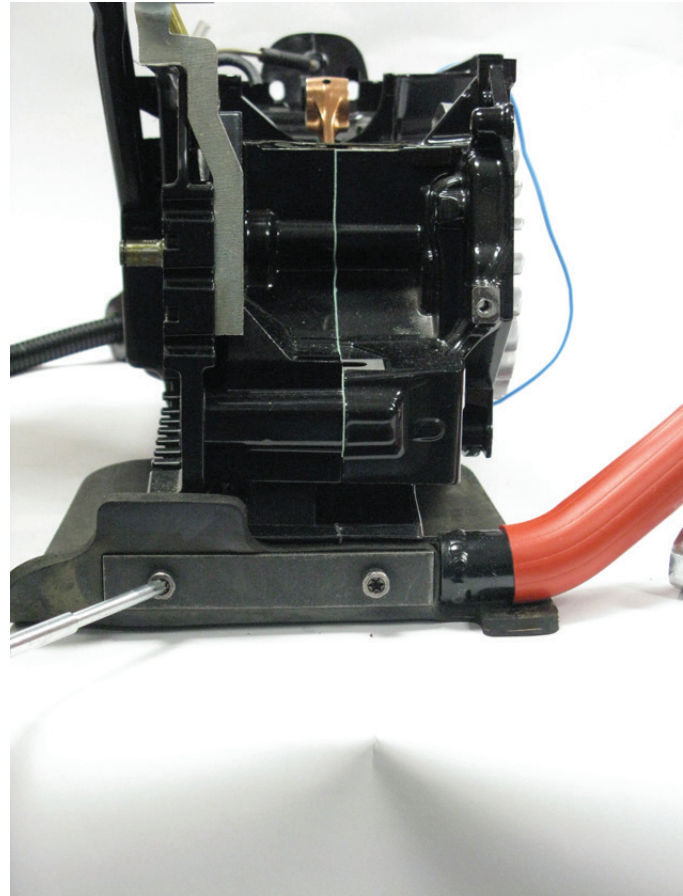

17.2

Remove (2) screws from lower front handle (P/N 544009).

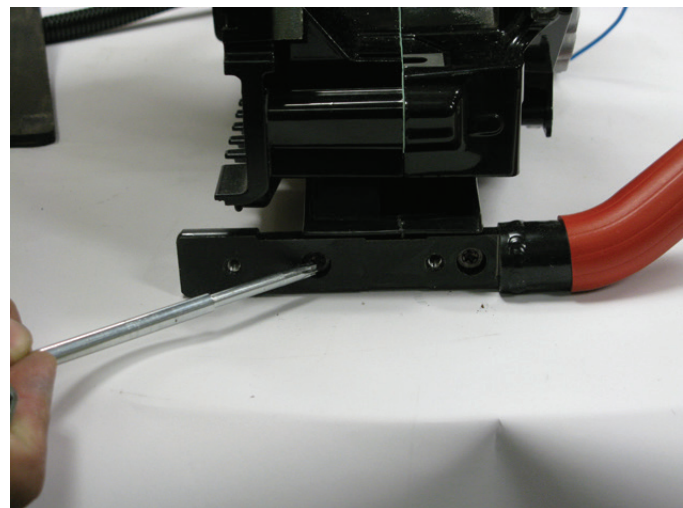

17.3

Remove (3) screws on the side of the handle (P/N 544009).

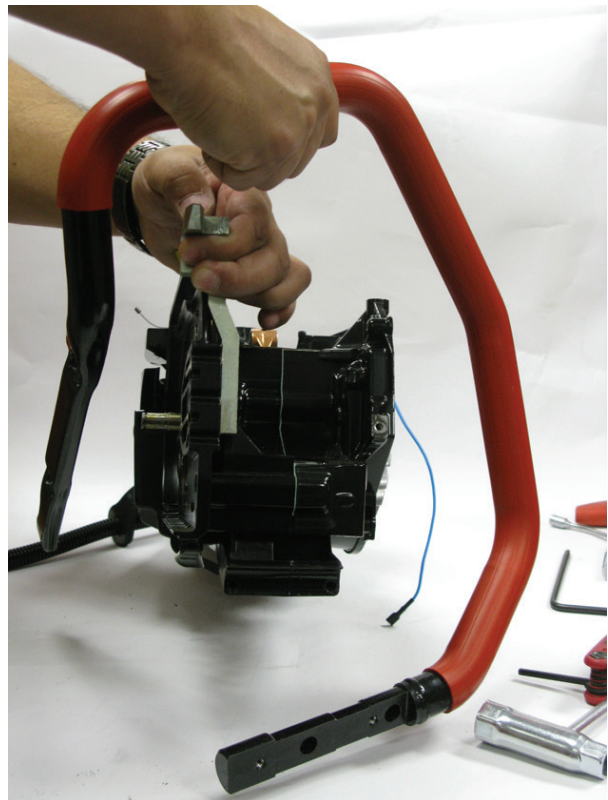
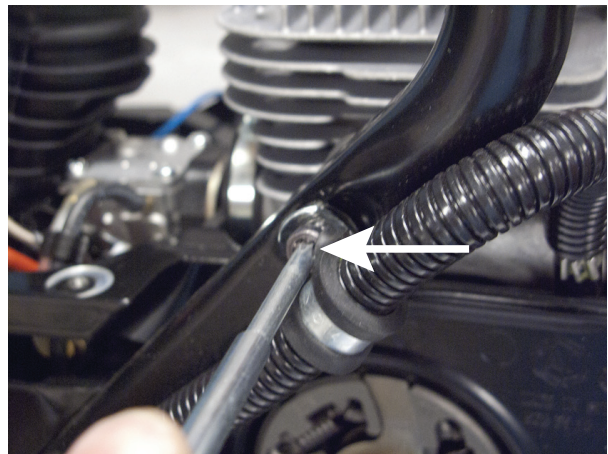
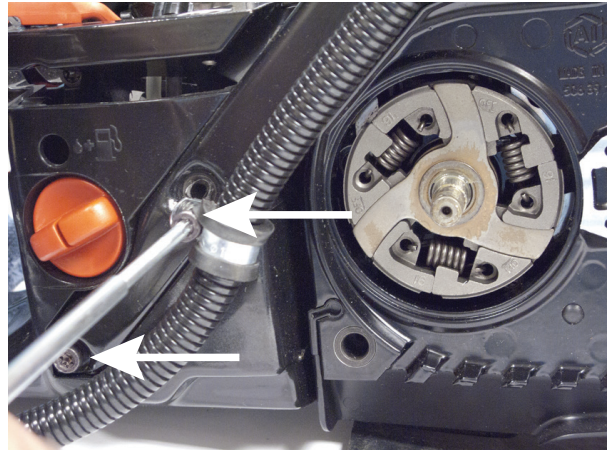

17.4

Lift up crankcase and remove handle, inspect and replace if damaged.

Install in reverse order

Use Loctite®242 on all screws except shock absorber screw.

18. This section covers the removal, inspection and installation of the rear handle.

18.1

Remove screw from rear handle (P/N 543974).



18.2

Remove rear handle cover (P/N 543816).



18.3

Remove throttle lock out (P/N 543815) by squeezing, pulling up and out.



18.4

Remove throttle trigger (P/N 543976) by pushing the (2) parallel pins (P/N 543813) from the rear handle housing.



18.5

Pull the throttle trigger and spring (P/N 543977) down from the rear handle.



18.6

Remove throttle cable (P/N 543975)
See section 10 to remove cable from
carburetor.

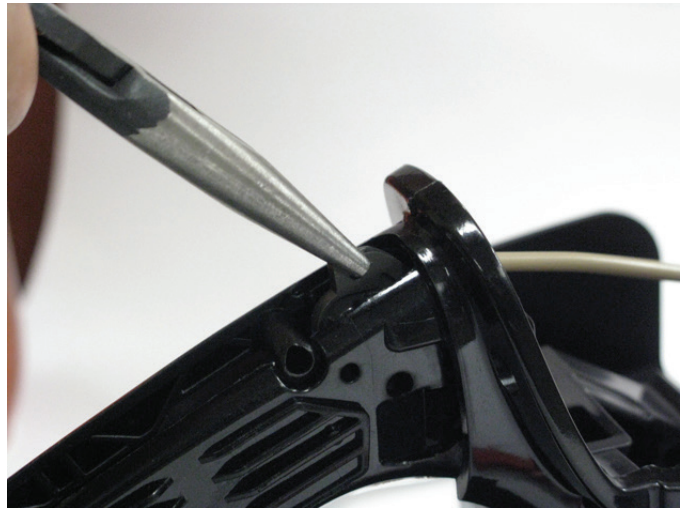

18.7

Remove cable lever (P/N 543814) using
needle nose pliers pulling up.

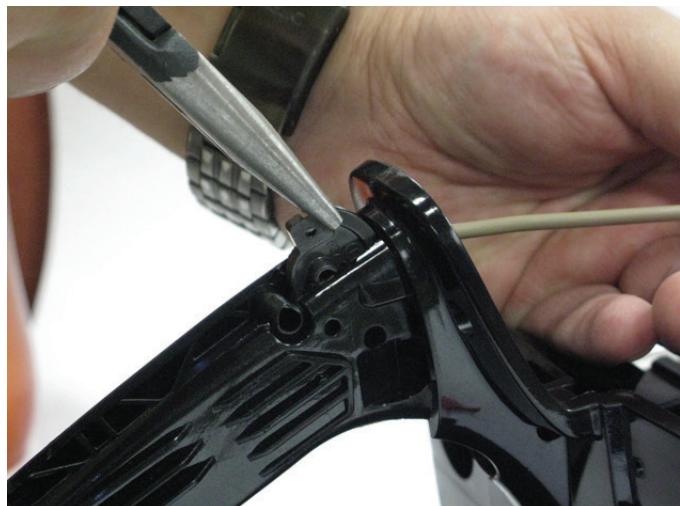

18.8

Remove throttle cable from cable lever using an awl or small punch.



18.9

Remove throttle cable through the front of the handle.

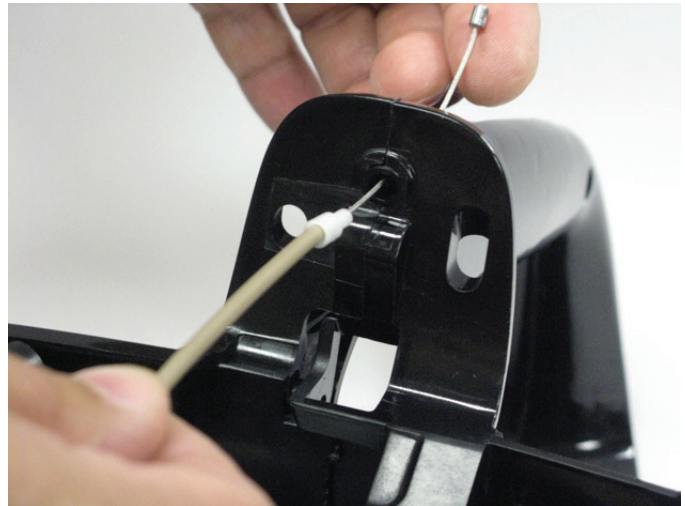

18.10

Inspect all throttle component parts.

- Replace if damaged.
- Reassemble in reverse order.



19. This section covers the removal, inspection, and assembly of the shock absorbers, fuel tank and components

19.1

Remove fuel cap (P/N 543979).

- Inspect fuel cap and O-ring.
- Replace if damaged.



19.2

Remove fuel filter (P/N 543971).

Use a small hook to remove filter from gas tank.



19.3

Remove fuel filter.

- Pull up on hose clamp (P/N 543970).
- Pull down on fuel filter.



19.4

Inspect fuel filter and line.

- Replace if damaged or dirty.
- Reassemble in reverse order.

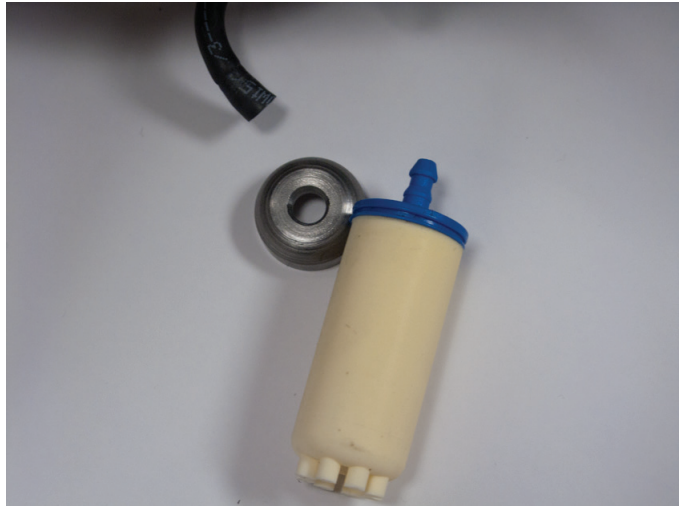

19.5

Before separating the fuel tank from crankcase, remove the front handle (see section 17) and throttle cable (see section 10).

Remove the (2) shock absorber screws from the clutch side of the saw.

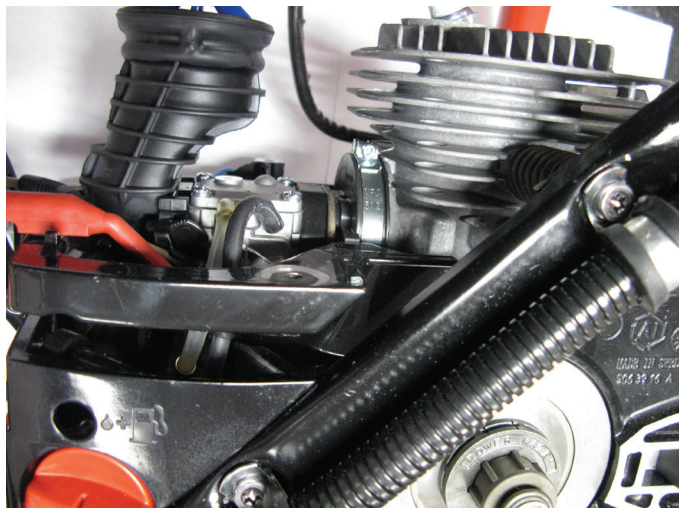

19.6

Remove the (2) shock absorber screws from the flywheel side of the saw.



19.7

Separate fuel tank from crankcase by pulling up on the crankcase while holding the fuel tank.

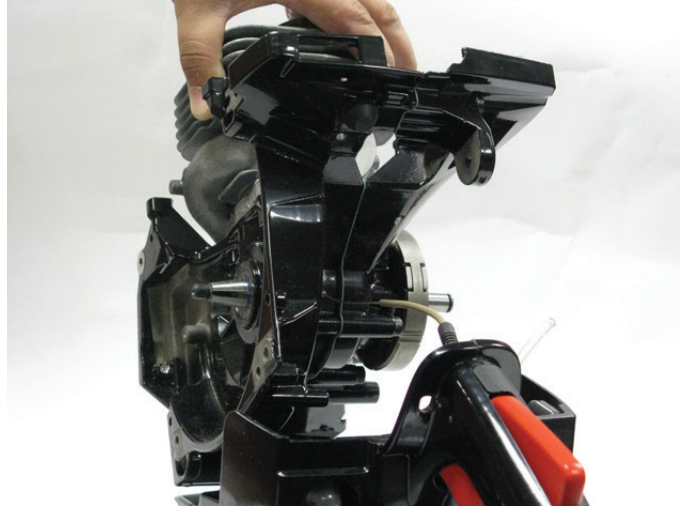

19.8

Inspect Tank Vent Assembly.

Location of the tank vent on a disassembled saw.

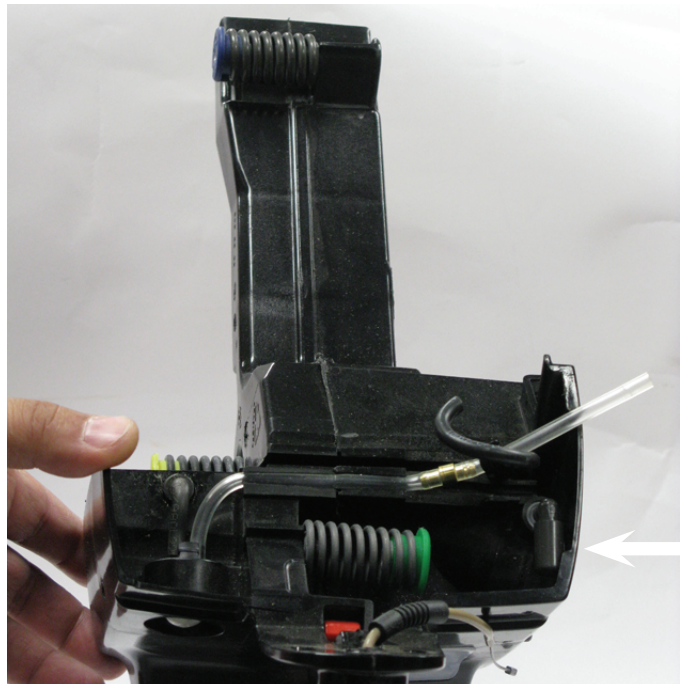

19.9

Location of the tank vent on an assembled saw.



19.10

Inspect the tank vent and replace if damaged.
Refer to troubleshooting (section 25) if necessary.



19.11

Inspect fuel tank for damage.

Replace if damaged.

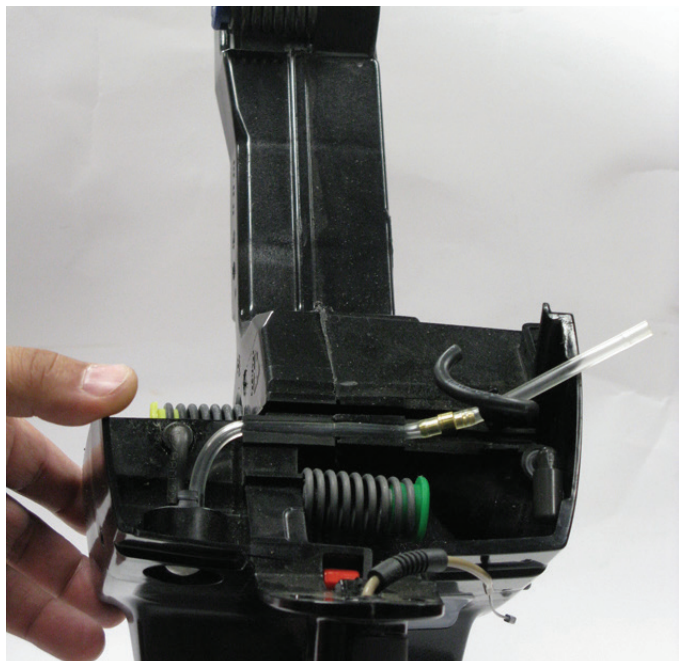

19.12

Shock Absorbers

Using the Workshop Key Torx T27 (P/N 546191), remove shock absorbers.

A.) Front shock absorber (P/N 543983).

B.) Clutch side shock absorber (P/N 543982).

C.) Flywheel side shock absorber (P/N 543984).

Inspect and replace if damaged.

Install in reverse order using Loctite® 242 (except Tank Vent).

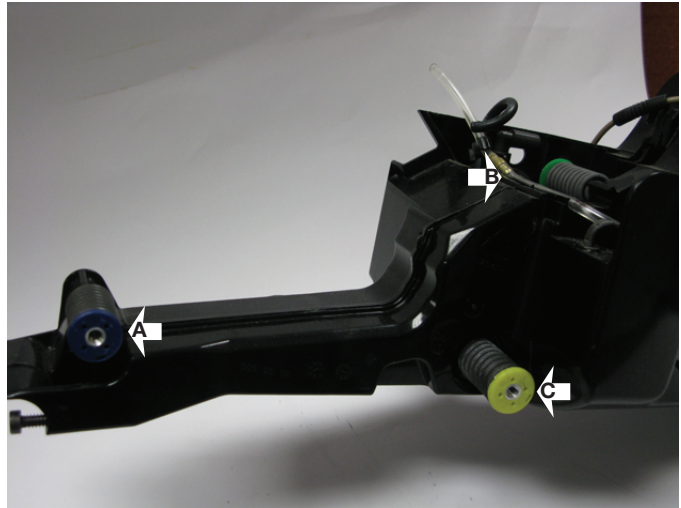

19.13

Purge bulb circuit.

Refer to troubleshooting (section 24) if necessary.

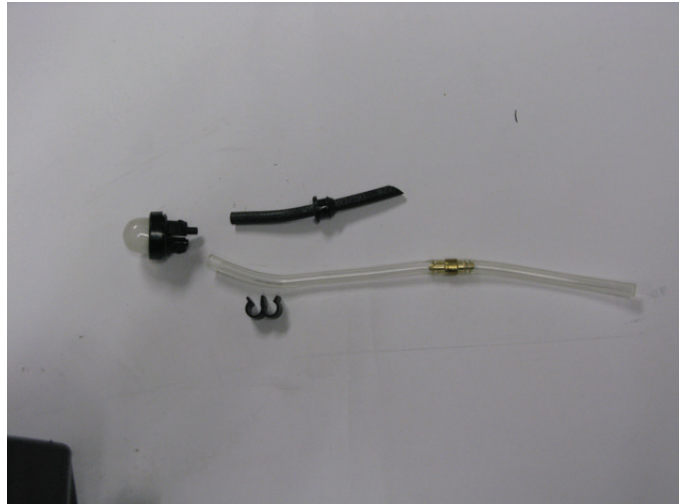

19.14

Disconnect the purge bulb tube, return line (P/N 543995) and disconnect check valve tube (P/N 543994).

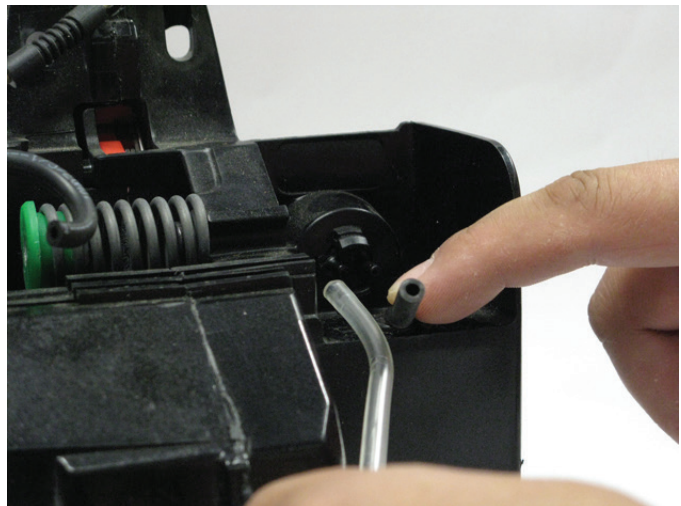

19.15

Remove purge bulb (P/N 543973) lightly depress tab to disengage purge bulb.

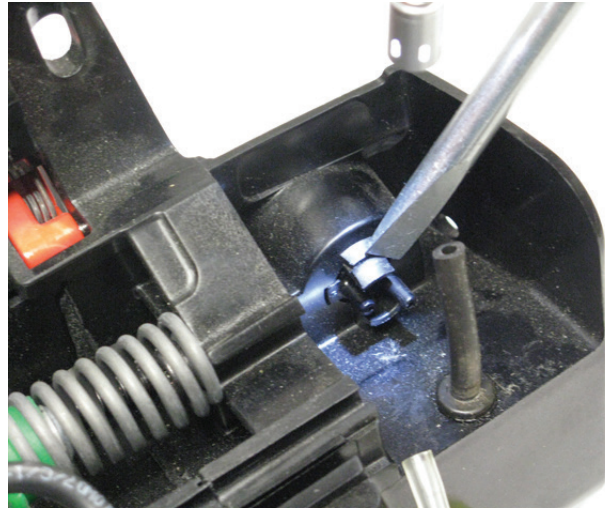

19.16

Inspect all components.

Replace if damaged. Check valve (P/N 543969) flows one way, ensure that it is installed correctly. Fuel flows towards the purge bulb.

Refer to troubleshooting (section 24) if necessary.

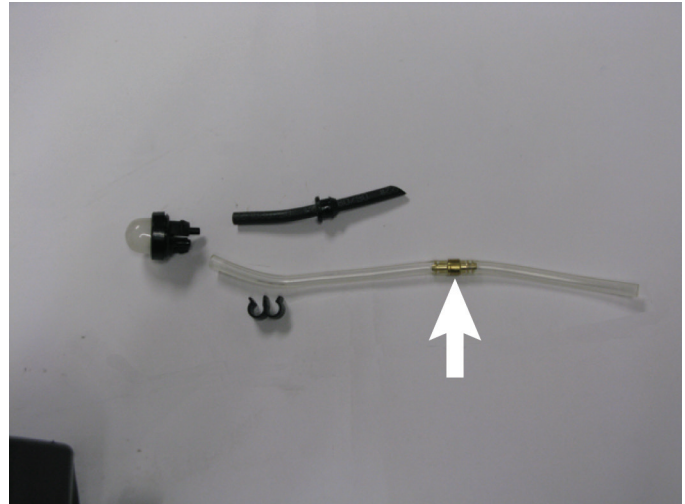

19.17

Reassemble in reverse order. Check valve tube must be inserted back into channel and connected to fuel line with clip. (P/N 543818).

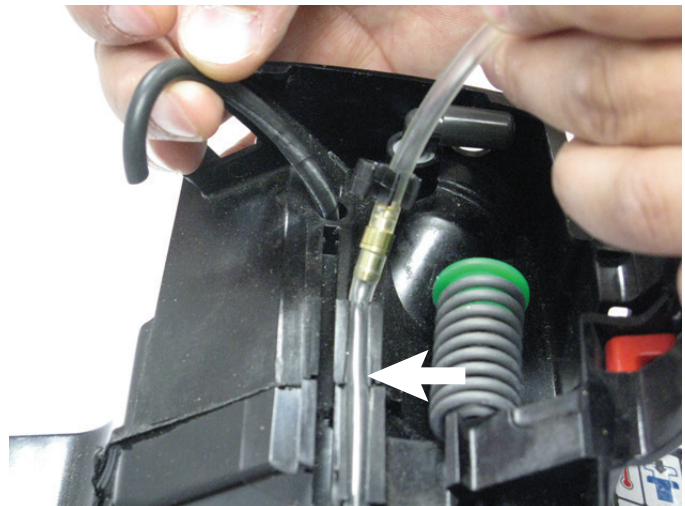

20. This section covers the disassembly, inspection and assembly of the crankcase seals and bearings.

20.1

Crankcase seal puller and punch.



20.2

Crankcase seals.



20.3

Seal removal.

A.) Insert T-handle puller over the shaft.
B.) Apply downward pressure to the T-handle and turn the barrel clockwise with a wrench to thread into the seal.



20.4

Turn the T-handle until it presses against the shaft and pulls the seal from the crankcase.

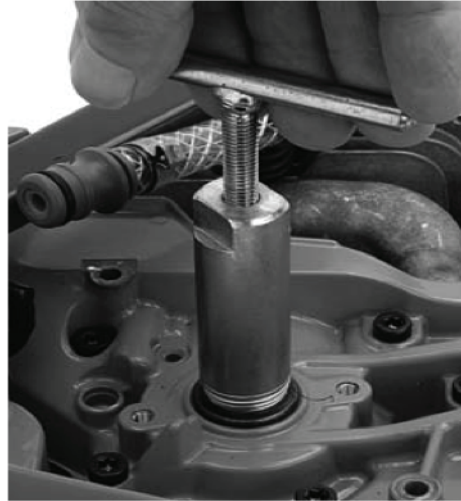

20.5

Lift off the seal and inspect the shaft for damage.



20.6

Lubricate the shaft with High Pressure Grease.



20.7

Install the new seal.

Use caution as seal slides over the threads.



20.8

Use the punch and soft mallet to tap seal into place.



20.9

Repeat procedure for the flywheel side.



20.10

Using soapy water on both sides, perform a crankcase leak down test using pressure gauge and vacuum gauge.



20.11

Use pressure gauge to perform a leak down test. Pressure should hold at 7 psi (0.5 bar).

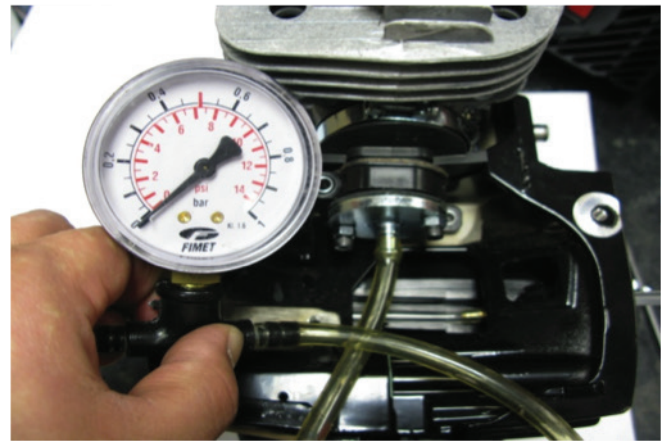

20.12

Crankcase separation.

The universal puller and grip plate are required to separate the crankcase.



20.13

Remove the shaft seals from both sides of the crankcase.

See seal removal.

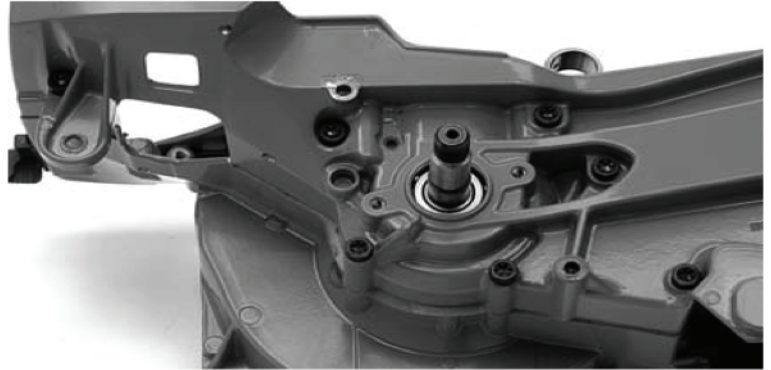

20.14

Install grip plate on the clutch side of the crankcase.



20.15

Attach universal puller and press out the crank shaft.



20.16

Using the same process, press out the other half from the flywheel side.

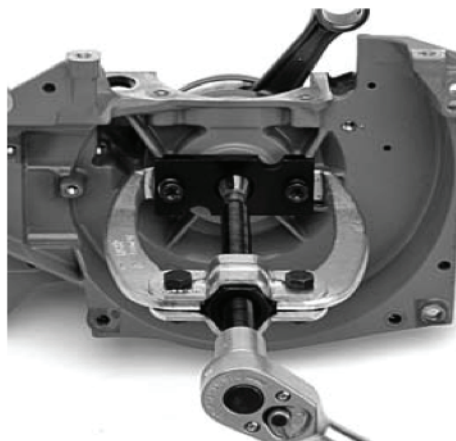

20.17

Separated crankcase halves with bearings installed.

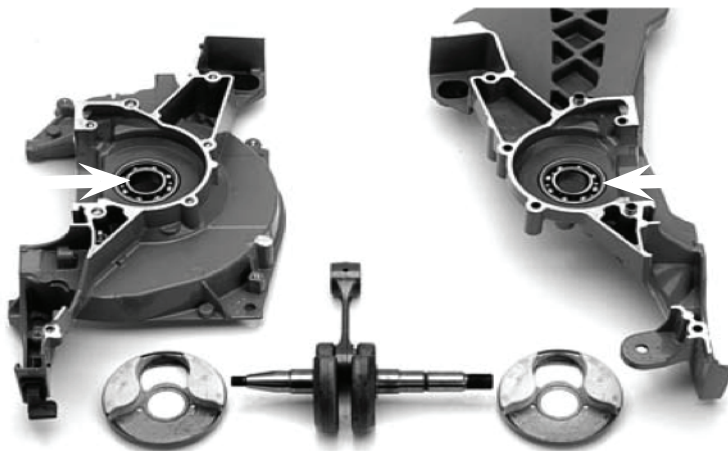

20.18

If the bearing(s) remain on the shaft upon separation, the bearing removal tool must be used.



20.19

Install the bearing clamp and tighten nuts.



20.20

Install the bearing puller and press the bearing off the shaft.

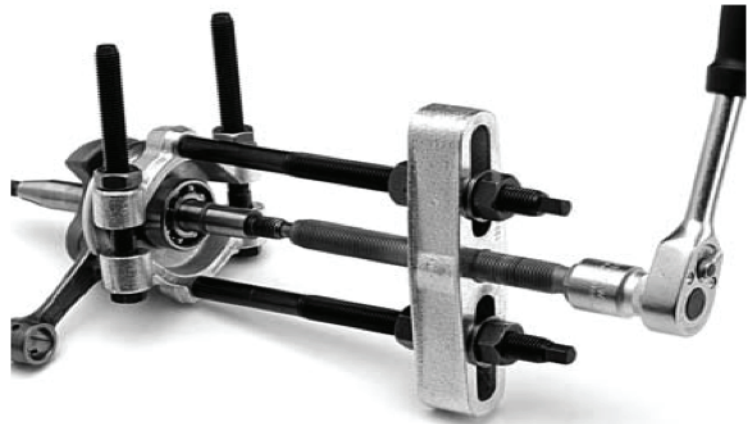

20.21

Crankcase bearing tools. These tools are required to remove the bearing from the crankcase.



20.22

Heat crankcase halves to 150°F (65.5°)
C. Use the shaft sleeve and soft mallet
to tap out both bearings.



20.23

Bearing installation.
Bearing press tools.



20.24

Place the bearing on the bearing support
plate. Holding the bearing support plate
under the crankcase half.

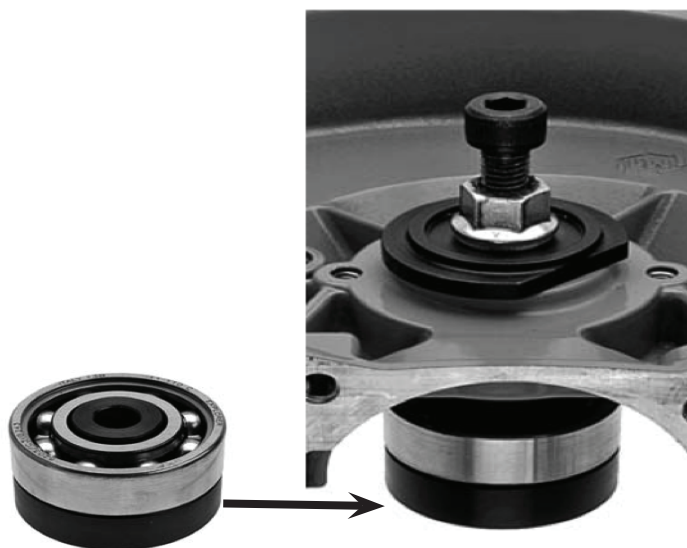

20.25

Place the screw with nut and washers through the crankcase support plate and thread into the bearing support plate.



20.26

Hold the screw in place and turn the nut until the bearing stops against the crankcase.

Repeat the process for the other half of the crankcase.

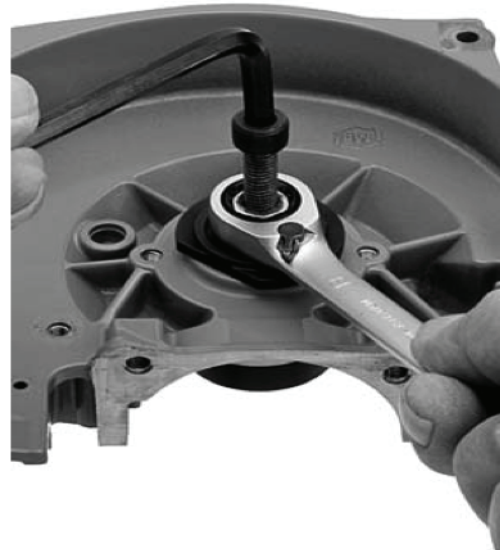

20.27

Bearing Tools.

Shaft Sleeve.
Shaft Mandrels.



20.28
Bearing press kit.



20.29
Crankshaft install.
Secure clutch side crankcase face down,
so the connecting rod is not pinched
against the crankcase.



20.30
Slide the clutch side shaft through the
bearing.

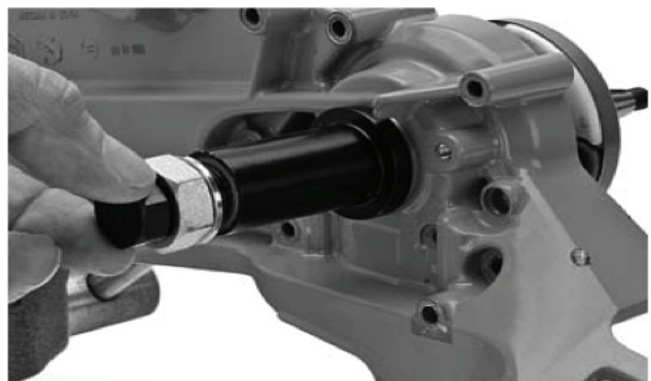

20.31

Slide the shaft sleeve over the shaft, against the crankcase. Thread the M12 mandrel with the nut and washer until it bottoms (Note - **REVERSE THREAD** on the clutch side).

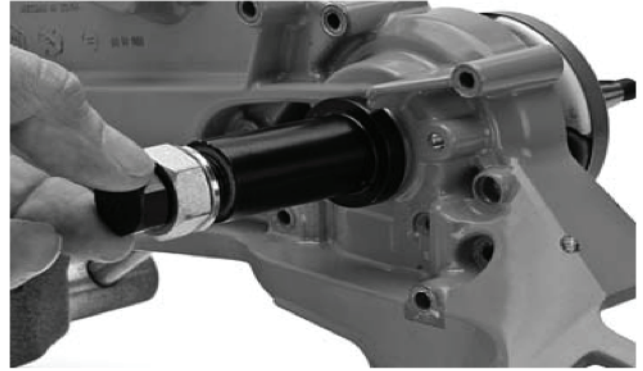

20.32

Hold mandrel in place, turn nut clockwise until the shaft reaches the top at the bearing. Ensure the connecting rod is not pinched against the case.



20.33

Install the (2) crankcase guide pins.

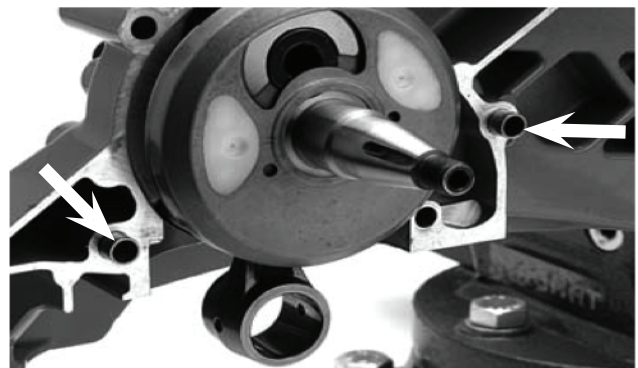

20.34

Lubricate the crankcase halves with ICS® 2-stroke oil and install the crankcase gasket.



20.35

Lubricate and assemble the flywheel side of the crankcase using the same method, with the M8 standard thread mandral. Ensure the connecting rod does not become pinched between the crankcase halves.

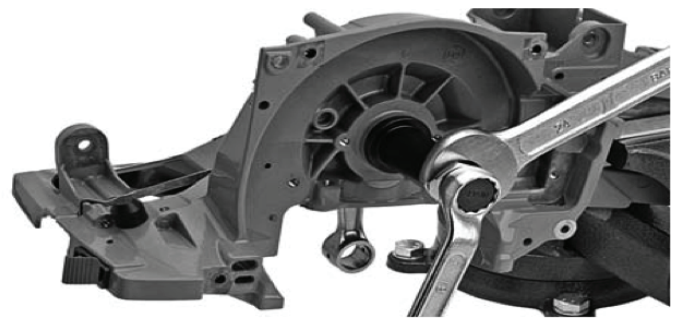

20.36

Loctite®242 and prefit the (8) screws and align the guide pins before bringing the crankcase together.

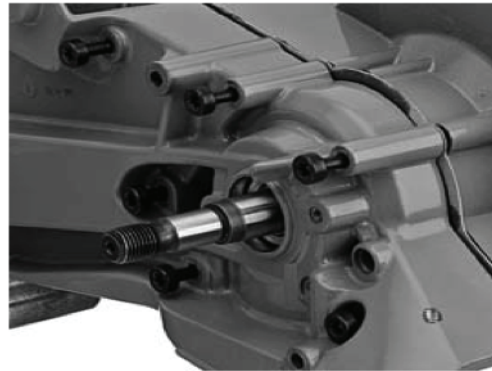

20.37

Tighten the screws to 106 - 124 in-lbs./
12 - 14 Nm using an "x" pattern.

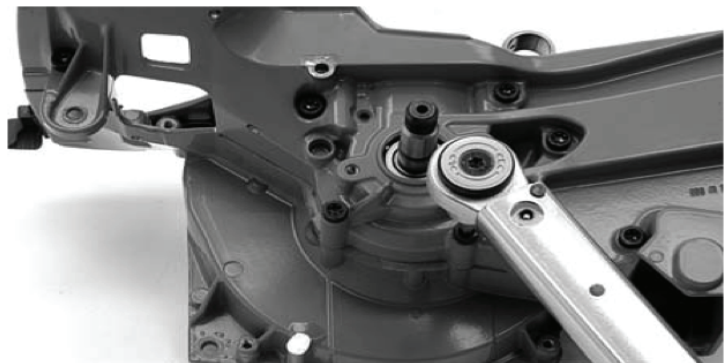

20.38

Cut the excess gasket over the cylinder port and carburetor area. Tap both sides of the shaft with a soft mallet and ensure free movement of shaft and connecting rod.



20.39

Install shaft seals (refer to section 20.7).



21. This section covers the carburetor tuning.

21.1

Carburetor tuning.

- A.) Throttle screw.
- B.) Low speed jet.
- C.) High speed jet.
- D.) Model number.

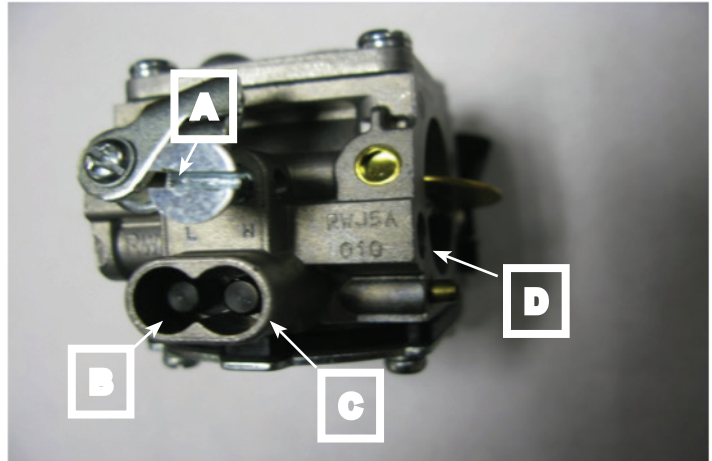

21.2

Tools required:
 Tuning screwdriver.
 Flat screwdriver.
 Tachometer.



21.3

Carburetor adjustment.

Tachometer is required for proper tuning of the saw.



21.4

Throttle screw.

Basic setting:

T = 3 turns from closed.

Used to adjust chain speed at idle.



21.5

Carburetor basic setting:

H= 1 1/2 turns from closed.

L= 1 5/8 turns from closed.

Insert the tuning screw driver into the crankcase slot. Note the H screw is on the right as seen in the picture.

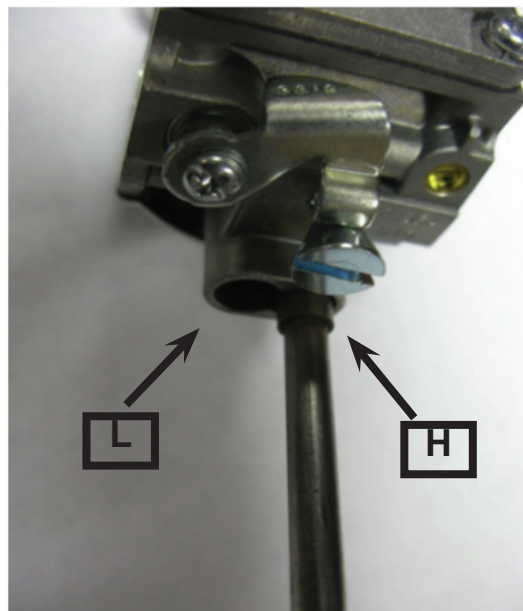

21.6

Turn both the H and the L needle screws clockwise until they stop.



21.7

Turn the screws counter clockwise to the carburetor basic settings.

Carburetor basic setting:

H= 1 1/2 turns from closed.

L= 1 5/8 turns from closed.



22.1

Verify the RPM's using the tachometer.

Start and warm up the saw.

NOTE: This is a “no load” tuning procedure. The side cover must be securely fastened with a bar and chain. **Water MUST be used, failure to follow this procedure may result in personal injury and or damage to the saw.**



22.2

Using the tachometer, check the saw RPM's at idle.

- Idle speed = 2700 RPM's +/- 150.
- Make minor adjustments using the throttle screw.

Using the tachometer, check the saw RPM's at full throttle.

- Full throttle target = 9300 RPM's +/- 150.
- Make minor adjustments using the throttle screw.

Do not hold the saw at maximum RPM for more than 5 seconds.

If the full throttle RPM falls below this range, turn the H needle clockwise 1/16 of a turn at a time, checking the RPM's at each interval.

NOTE: pulse the throttle to stabilize the system.

Once the carburetor is adjusted, install the chain to the proper tension and continue normal operations.



23. This section provides several flowcharts to aid diagnosing common problems.

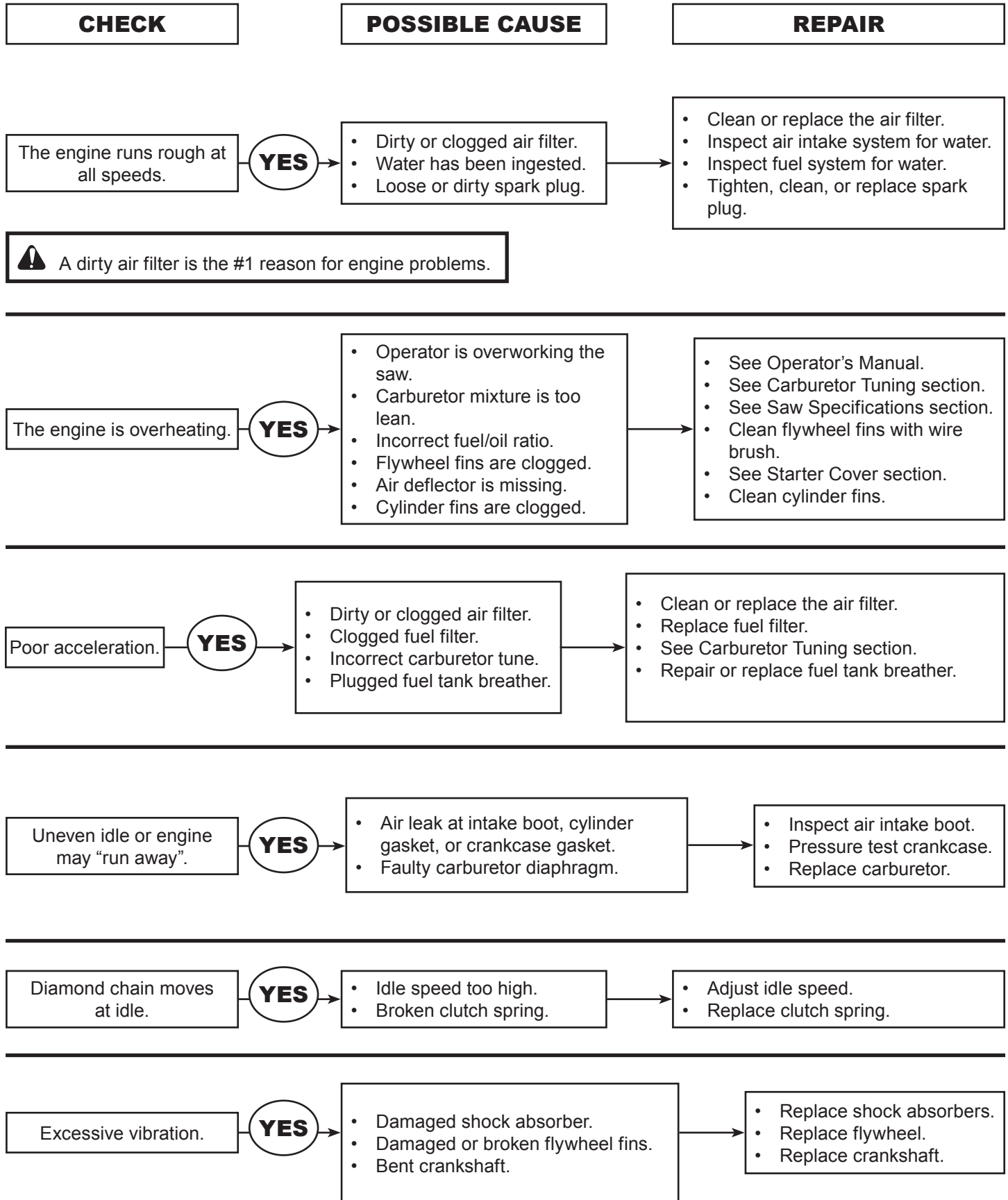

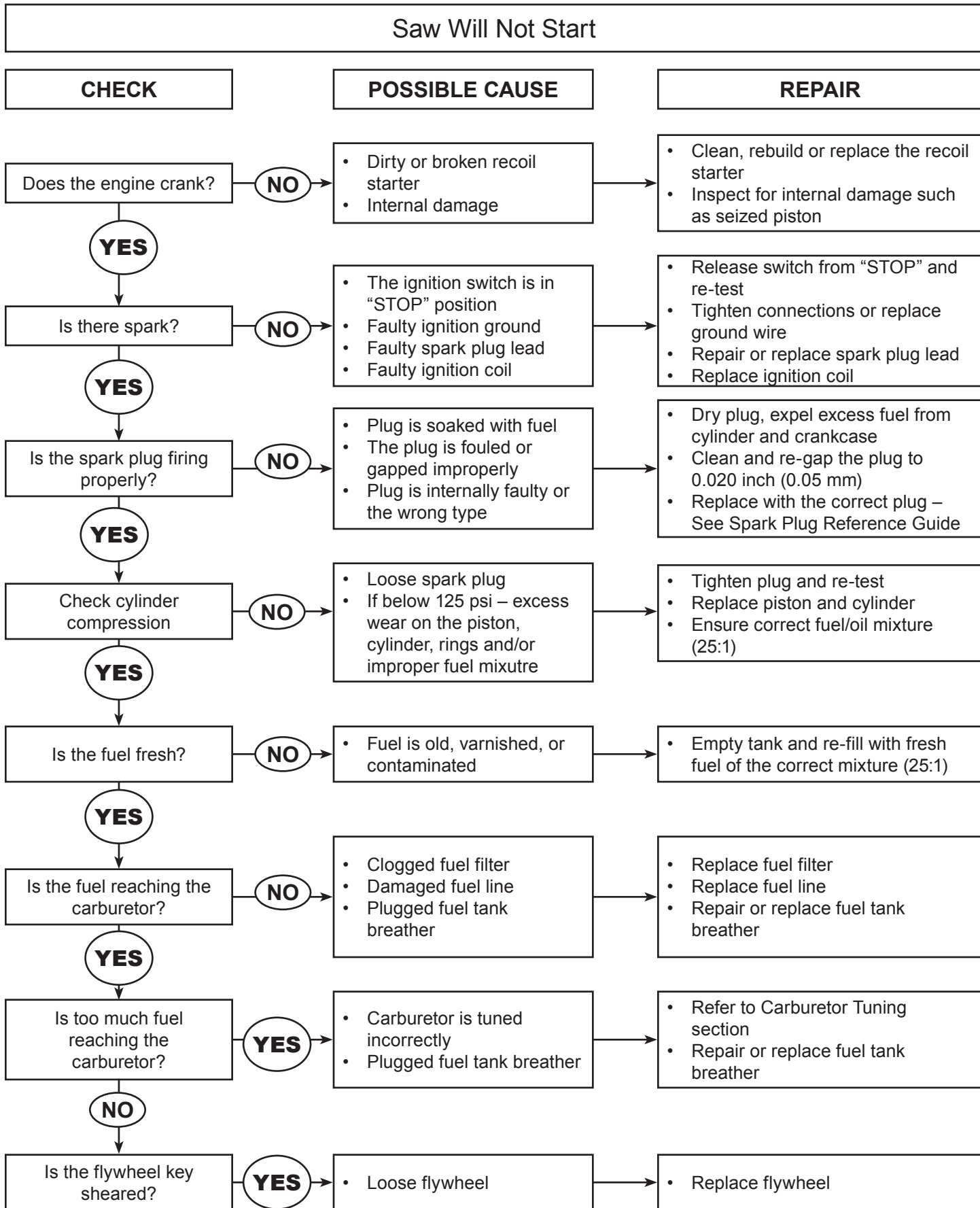

24. This section covers testing the fuel system.

24.1

Engine starvation can result from a leak or malfunction of any of the main components of the fuel system.



24.2

The main components are the fuel tank, fuel tank breather, fuel filter, purge bulb, delivery tubes and carburetor.



24.3

Remove and inspect the fuel filter.

Replace the fuel filter if the filter is excessively dirty or there is foreign material stuck to it.



24.4

Test the main fuel pick-up for leaks.

Install the pressure gauge and bulb to the filter end of the fuel line.

Pressurize the tube to 7psi (0.5 bar)

If the pressure does not maintain, separate the fuel line from the carburetor

**24.5**

Plug one end of the fuel pick-up tube.

Pressurize the tube to 7 psi (0.5 bar).

If the pressure holds, the leak has been isolated to the carburetor. Refer to the Walbro Carburetor Service Manual.

<http://wem.walbro.com/distributors/servicemanuals>

**24.6**

The fuel tank breather stabilizes the pressure in the fuel tank preventing both excessive pressure, which could flood the engine and negative pressure which could starve the engine of fuel.



24.7

The fuel breather is located above the fuel cap on top of the fuel tank.

**24.8**

Testing the fuel tank breather.

Attach the pressure gauge to the fuel tank plug. Plug the fuel line at the carburetor end. Pressurize the tube to 4.5 psi (0.3 bar).

The pressure should reduce to nearly 0 psi (0 bar) over a period of 3 seconds.



24.9

If the pressure does not release, disassemble or replace the breather.



24.10

Inspect the fuel purge circuit.

Inspect the purge bulb for leaks or damage. Replace if damaged. See fuel tank section.



24.11

Inspect fuel purge lines and one way purge valve for leaks or damage. The arrow is the purge flow direction.

Replace if damaged. See fuel tank section.

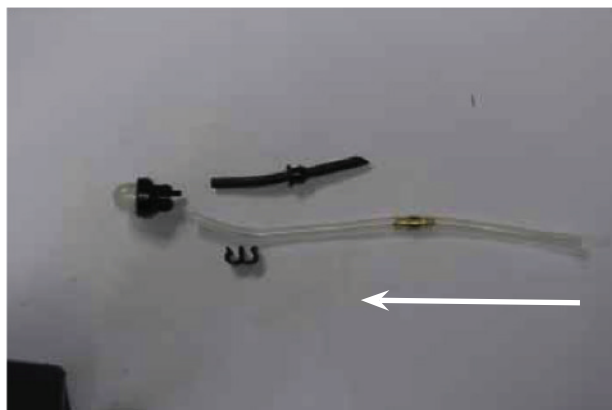

25.1

This section covers testing the the crankcase for leaks. A leak in the crankcase can cause the engine to run too lean, causing engine damage, or not run at all.

- A.) Exhaust Seal Flange.
- B.) Intake Seal Flange.

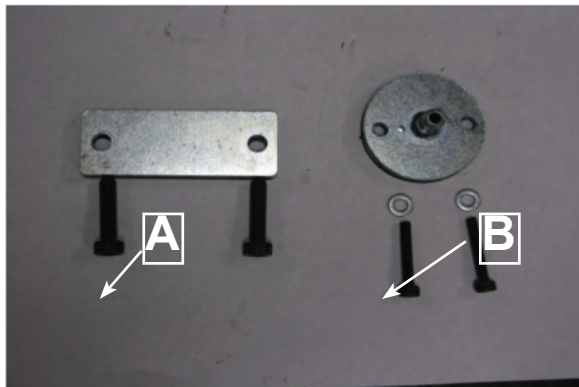

25.2

With the carburetor and muffler removed, block the intake and exhaust ports with the seal flanges.

See Cylinder Cover and Muffler sections.

NOTE: Remove intake plate from intake boot prior to installing intake seal flange.



25.3

Securely plug or tape over the clutch needle roller lubrication port on the crankshaft.

Clutch cup and needle roller must be removed. See Clutch Cup and Rim Sprocket Section (section 8).

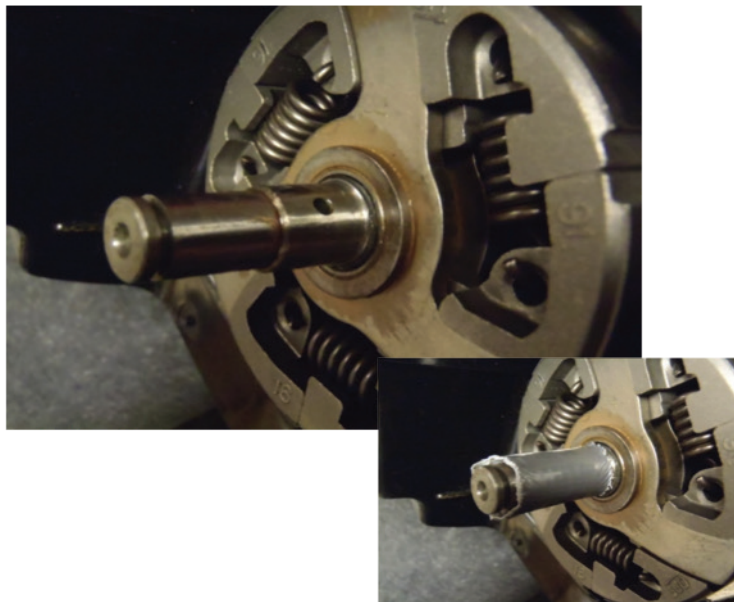

25.4

Install the exhaust seal flange.

Use the muffler mounting screws to install the flange.

Be sure the spark plug is secure and the decompression valve is pulled out.

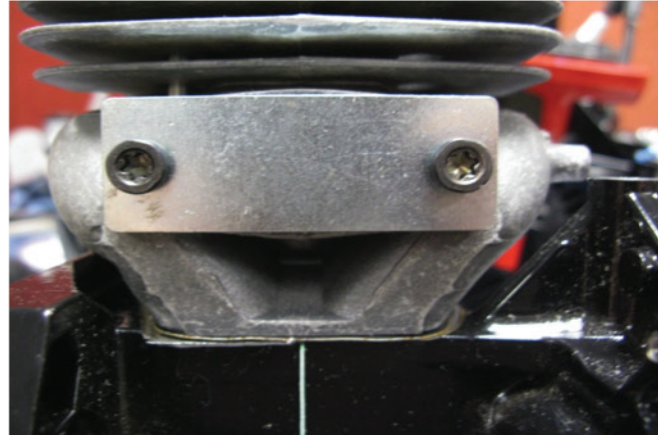

25.5

Install the intake seal flange.

Use M4 x 20 screws w/ washers (not supplied) to secure the seal flange.

Install the pressure gauge and pressurize the crankcase to 7 psi (0.5 bar). If the pressure does not hold, use soapy water to find the leak.

Note: it is recommended to pressure test the engine after a piston and cylinder rebuild, and or crank seal replacements.

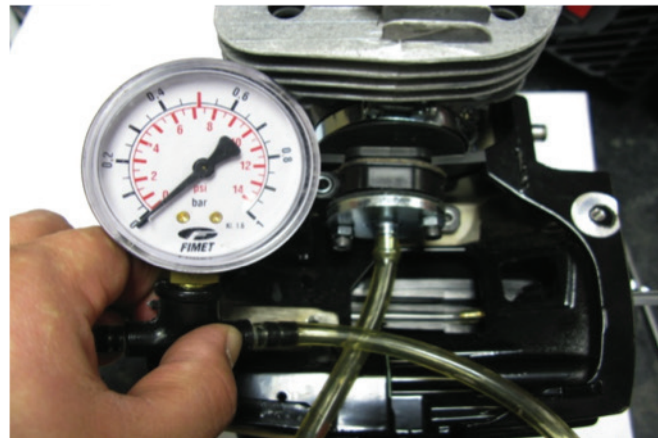

This appendix covers the removal, inspection, and installation of the spark plug for the 695GC & 695F4.

Remove the spark plug lead.

Clean area around the spark plug to prevent debris from entering the cylinder.



Remove the spark plug.



Inspect the spark plug.

If dirty, clean with a wire brush as shown.



Gap if necessary to 0.02" (0.5 mm).

**695GC: Champion RCJ-6Y
or NGK-BPMR7A**

**695F4: Champion RCJ-6Y
or NGK-BPMR7A**

Assemble in the reverse order.



Make sure the plug boot is seated completely.



695 SERVICE MANUAL

**ICS, Oregon Tool, Inc.
4909 SE International Way
Portland, OR 97222, USA
Tel 800.321.1240**

**ICS, Oregon Tool Europe S.A.
Rue Emile Francqui, 5
1435 Mont-Saint-Guibert, Belgium
Tel +32 10 301 251
icsdiamondtools.com**